



Dear Exhibitor:

As the Official General Service Contractor, we would like to welcome you to **Demolition Phoenix**.

We have, along with Show Management, compiled this Exhibitor Services Manual to provide you with all of the necessary forms and vital information that you will need for a successful exposition experience.

In order to qualify for discount prices where available, please take time to review this manual now. To receive the discount prices your order(s) along with full payment must be received by the date indicated on the particular form. Please do not miss out on this opportunity to secure discounted prices. The savings offered to you are substantial.

Should you have any questions regarding any of the services or need assistance in planning your exhibit, please do not hesitate to contact our customer service department at 253 437 0031 or via email at operations@levyexpo.com. We will be happy to assist you in any way possible to ensure that you have a successful experience at **Demolition Phoenix**.

Thank you and we look forward to servicing your needs at **Demolition Phoenix** in **Phoenix, Arizona**.

Sincerely,

Levy Exposition Services, Inc.

| | | |
|-------------------------------------|-------------------------------------------------------------------------------------------------------------------------------------------------------------------------------------------------------------------------------------------------------------------------------------------------------------------------------------------------------------------|------------------------------------------------------|
| SERVICE CONTRACTOR CONTACT: | LEVY EXPOSITION SERVICES INC. 14900 Interurban Avenue S., Suite 271 Seattle, WA 98168 T: 253 437 0031 F: 253 437 0032 E: operations@levyexpo.com | |
| LOCATION: | Phoenix Convention Center 100 N 3 rd Street Phoenix, AZ 85004 | |
| EXHIBITOR MOVE-IN: | Tuesday, February 21, 2023 | 8:00 am – 5:00 pm <i>(equipment spaces only)</i> |
| | Wednesday, February 22, 2023 | 8:00 am – 5:00 pm |
| | Thursday, February 23, 2023 | 8:00 am – 5:00 pm |
| EXHIBITION DATES: | Thursday, February 23, 2023 | 6:30 pm – 8:00 pm <i>(Expo Opening Reception)</i> |
| | Friday, February 24, 2023 | 10:30 am – 4:00 pm |
| | Saturday, February 25, 2023 | 10:00 am – 1:00 pm |
| EXHIBITOR MOVE-OUT: | Saturday, February 25, 2023 | 1:00 pm – 8:00 pm |
| | Sunday, February 26, 2023 | 8:00 am – 12:00 pm |
| | **Please note that all exhibit materials must be removed from the exhibit Facility by 12:00 pm on Sunday, February 26, 2023. | |
| BOOTH EQUIPMENT: | Each 10' x 10' booth space includes the following: <ul style="list-style-type: none"> • 8' high drapery backwall – black • 3' high drapery sidewall – black • 1 - 7" x 44" booth identification sign <p>If you require additional furnishings or services please complete and return the appropriate enclosed order form(s).</p> | |
| AISLE CARPET: | The aisles will be carpeted in Tuxedo. Tuxedo carpet is a mix of black, white and grey. | |
| CEILING HEIGHT: | The ceiling height in the exhibit hall is 30'. | |
| SUSPENDED SIGN HANGING: | All overhead hanging must be assembled, installed, and removed by Levy. Please complete the enclosed Labor Order Form for labor to assemble your hanging sign. Sign assembly requires a two person crew. | |
| PRESSURE WASHING: | Pressure washing and detailing services will not be available. | |
| DISCOUNT PRICE DEADLINE: | In order to receive the discount rates listed on the enclosed order forms, your PAID order is to be received by February 1, 2023 . | |
| LEVY ONLINE ORDERING (LOLO): | The online ordering link and instructions will be sent via email to all exhibitors. Please provide your correct contact information to the show organizer to ensure you receive all necessary show information. | |

MARSHALLING YARD: We will utilize a marshalling yard for driver check in during the move-in and move-out of Demolition Phoenix with a check-in fee of \$30.00 in and out. The marshalling yard is located at A 1102 E Tonto Street in Phoenix, AZ 85034. It is mandatory that ALL inbound and outbound carriers report to the marshaling yard and check in prior to being dispatched to the loading dock. The marshalling yard will be operational during the following dates:

Tuesday, February 21st: 8am - 5pm
Wednesday, February 22nd: 8am - 5pm
Thursday, February 23rd: 8am - 5pm
Saturday, February 25th: 9am - 8pm
Sunday, February 26th: 8am -12pm

Please note that overnight parking in the marshalling yard is not permitted.

SHIPPING: Please refer to the Material Handling order form in this manual for further information and associated costs.

All ADVANCE WAREHOUSE shipments should arrive between January 18, 2023 – February 15, 2023. Shipments arriving before or after these dates will incur an early/late surcharge.

Shipments sent to the advance warehouse should be consigned as follows:
(Labels are provided in the Material Handling Section of the manual)

Demolition Phoenix
Exhibiting Company Name
Booth # ____
Levy Exposition Services, Inc.
c/o Liberty CFS NV, Inc.
2021 S 51st Ave
Phoenix, AZ 85043

All **DIRECT** shipments should not arrive prior to 8:00 am on **Wednesday, February 22, 2023**. Shipments arriving prior to this time will be refused.

Direct shipments should be consigned as follows:
(Labels are provided in the Material Handling section of manual)

Demolition Phoenix
Exhibiting Company Name
Booth # ____
Phoenix Convention Center
c/o Levy Exposition Services, Inc.
100 N 3rd Street
Phoenix, AZ 85004

**DISMANTLE AND
MOVE-OUT
INFORMATION:**

All exhibitor materials **MUST** be removed from the facility by 12:00 pm on Sunday, February 26, 2023. To ensure that all exhibitor materials are removed by this time, please have your carrier check in at the Marshalling Yard no later than 9:00 am on February 26th. In the event that your carrier does not check-in at the Marshalling Yard by this time, your shipment will be rerouted via the official carrier, Liberty CFS NV, Inc.

**POST SHIPPING
PAPERWORK:**

Our customer service center will have outbound bills of lading and shipping labels for your convenience. Please note that Levy Exposition Services Bills Of Lading's (BOLs) **MUST** be filled out and turned into the service center once your materials are packed for all outbound shipments.

It is vital that your carrier knows your company name and booth # when you make your outbound shipping arrangements. Additionally, if your carrier plans to use a freight forwarding company to pick up your shipment(s), you **MUST** include this company's name as well as the actual shipping company's name on the bill of lading that you fill out. In the event someone other than the company listed on your outbound bill of lading arrives to pick up your shipment, it will be rerouted via the official show carrier.

SHOW SITE WORK RULES IN ARIZONA

To assist you in planning for your participation in the show, we are certain you will appreciate knowing in advance that Levy labor will be required for certain aspects of your exhibit handling.

To help you understand the show site work rules, we ask that you read the following.

EXHIBIT INSTALLATION AND DISMANTLING

Stagehand Local #336 has jurisdiction via a labor agreement with Levy for the erection, touch-up, dismantling and repair of all exhibits when this work is done by persons other than your fulltime company personnel. This work is to include wall coverings, floor coverings, pipe and drape, painting, hanging of signs and decorative materials from the ceiling, placement of all signs and the erection of platforms used for exhibit purposes.

Jurisdiction does not cover the placement of your products on display, the opening of cartons containing your products, or the performance, testing, maintenance or repairs of your products.

If full-time company personnel are utilized to set an exhibit, they must carry company identification such as a medical identification card or a payroll stub.

The utilization of workers hired from a non-union agency or company is prohibited.

To secure labor, please complete the labor forms enclosed.

MATERIAL HANDLING

Stagehand Local #336 has jurisdiction via a labor agreement with Levy for the loading and unloading of all trucks, trailers, and common and contract carriers as well as the handling of empty containers and the operation of material handling equipment. It also has the jurisdiction for the unloading, uncrating, unskidding, leveling, painting and assembly of machinery and equipment as well as the reverse process.

Levy has the responsibility to manage docks and schedule vehicles for the smooth and efficient move-in/move-out of the trade show. Levy will not be responsible for any material it does not handle.

Exhibitors may "hand carry" material provided they do not use material handling equipment to assist them. When exhibitors choose to "hand carry" material, they may not be permitted access to the loading dock/freight door areas.

GRATUITIES

Levy requests that exhibitors do not tip its employees by giving money, merchandise, or other special consideration for services rendered. Exhibitors should not give coffee breaks other than mid-morning and mid-afternoon when Levy employees have a fifteen minute paid break. Any attempts to solicit a gratuity by an employee for any service, should be reported immediately to a supervisor of Levy. Levy employee(s) are paid an excellent wage, and tipping is not an accepted company policy.

IN GENERAL

Craftsmen at all levels are instructed to refrain from expressing any grievances or directly challenging the practices of any exhibitor. All questions arising with regard to Levy's jurisdiction or practices must be directed to a Levy management representative.

SAFETY RULES

Exhibitors must provide adequate space within the exhibit to allow for the comfort and safety of persons watching demonstrations and/or placing orders. Each exhibitor is responsible for keeping the aisles near their booth free of congestion which may be caused by such demonstrations and/or order placement.

Aisles **MUST** remain free and clear of all obstructions. If chairs are being used as part of your exhibit, they **MUST** remain inside your booth space. Chairs in the aisle constitute a violation of fire codes and are also considered a booth violation.

Do not run electrical cords or position displays and/or product in such a way as to pose a safety hazard for attendees and company personnel who will traffic into booth areas.

Do not store cardboard cartons or packing materials in booth areas, as this is a violation of fire codes and poses a safety hazard.

Do not place product samples, whether on tables or free-standing displays, at the edge of the aisle, or in the case of an island booth, on shelving units on an outside wall. All portions of an Exhibitor's display must be contained within his/her assigned booth space, including chairs placed at the edge of an aisle.

At the close of the exhibit hall, please keep clear of all aisles including exhibit material and/or product. During the first two or three hours after the close of the exhibit hall, there is ample traffic in the aisles including but not limited to forklift traffic returning empty containers.

DEMOLITION PHOENIX

Where the future begins

Phoenix, AZ

February 22-25, 2023

GENERAL SHOW INFORMATION & INSTRUCTIONS

A. IMPORTANT DATES AND TIMES

Exhibitor Move-In:

Tuesday, February 21 Equipment Move-In Only

Levy to send targeted move-in times to individual exhibitors based on position on floor plan.

Wednesday, February 22 8:00am – 5:00pm - All Exhibitors

Thursday, February 23 8:00am – 5:00pm - All Exhibitors

All exhibits must be set-up by 5:00pm on Thursday, February 23, 2023.

Expo Hours:

Thursday, February 23 6:30pm – 8:00pm

Friday, February 24 10:30am – 4:00pm

12:00pm – 1:00 pm (Lunch in Expo)

Saturday, February 25 10:00am – 1:00pm

12:00pm – 1:00 pm (Lunch in Expo)

Exhibitor Move-Out:

Saturday, February 25 1:00pm - 8:00pm

Sunday, February 26 8:00am – 12:00pm

The Expo will be open according to the schedule shown above. All exhibits must be opened and staffed during the show hours. Exhibitors will be allowed into the Expo **two hours** prior to the opening. Exhibitors will be required to exit the Expo as soon as the show closes each night.

Exhibitors may begin to pack equipment, supplies and literature when the show closes on Saturday, February 25 at 1:00pm and must be completely out of the hall by Sunday, February 26 at 12:00pm. Any materials remaining in the facility will be re-routed via Levy's choice at the exhibitor's expense. All carriers must check-in at the Marshalling Yard no later than 9:00am on February 26th.

B. EXPO ADMISSION HOURS

Exhibitors will be allowed on the Expo floor at the following times:

Tuesday, February 21 Equipment Move-In Only

Wednesday, February 22 8:00am – 5:00pm

Thursday, February 23 8:00 am – 8:00pm

Friday, February 24 8:30am – 4:00pm

DEMOLITION PHOENIX

Where the future begins

Phoenix, AZ

February 22-25, 2023

Saturday, February 25 8:00am – 8:00pm
Sunday, February 26 8:00am – 12:00pm

Exhibitors must have a name badge in order to gain access to the Expo. If an exhibitor needs additional time in their booth during exhibitor move-in/move-out, please contact NDA Show Management onsite to receive an Early/Late Pass. Stop by registration for assistance.

C. OFFICIAL SERVICE AND MATERIAL HANDLING CONTRACTOR

Levy is the Official General Service Contractor for 2023 Demolition Phoenix. Other official show suppliers are listed in the Exhibitor Services Directory. Levy will maintain an Exhibitor Service Desk located in the back of the Expo during the event, move-in and move-out.

D. SHIPPING & INSURANCE

Shipping instructions and shipping labels are included in the Levy materials. NDA encourages exhibitors to purchase insurance coverage for their booth in the event your display is damaged or lost in transit.

While making shipping arrangements, be sure to plan for a company representative to be on-site to oversee the outbound shipment of your display and products. It is also a good idea to place a rider on your insurance policy to cover your display and products from the time they leave your possession until their return. Remember that your company is responsible for your exhibit and product. It is expected that exhibitors have or purchase adequate insurance to protect against all perils. Your insurance agent should be consulted to be sure of adequate coverage.

E. TRUCK DELIVERIES

All truck drivers delivering freight to the show should check in with the shipping and receiving dock at the convention center. Freight will be unloaded on a first-come, first-served basis in accordance with Levy's move-in schedule, the availability of appropriate manpower and equipment for the job and access to the exhibitor's booth location.

F. EMPTY CRATES

It is important that crates be removed from the floor and placed in storage as soon as they are empty. All crates should be closed securely and "empty" stickers should be attached as soon as they are emptied. Stickers can be picked up at the Levy Exhibitor Service Desk located in the back of the Expo. Open crates will not be accepted for storage.

A clearly marked "empty" sticker containing your booth number and company identification securely attached to your empty crates will expedite their return to you at the close of the show. No empty boxes or crates may be stored in the exhibit area or in the service aisle due to Fire Marshal regulations.



DEMOLITION PHOENIX

Where the future begins

Phoenix, AZ

February 22-25, 2023

G. SECURITY

Independent guards will be engaged to provide protection for the overall exhibition from the beginning of move-in to the end of move-out, but not for any particular exhibit. The National Demolition Association (NDA), SmithBucklin, Levy, the Phoenix Convention Center and the security vendor are not responsible for the safety of the property of exhibitors from theft, damage by fire, accident, vandalism or other causes. NDA strongly recommends that each exhibiting company secure a rider policy through its insurance agent to cover all booth and display items during transportation to and from this convention, as well as during installation, exhibit days, and dismantling. NDA insurance policies do not extend to cover liabilities of exhibitors.

H. HOUSING INFORMATION

NDA has reserved a block of rooms at the Sheraton Phoenix Downtown. To take advantage of these rates, please click on the link below and reserve your room today!

Sheraton Phoenix Downtown
340 North 3rd Street
Phoenix, AZ 85004

\$259.00/night

[Book your reservation online at the Sheraton!](#)

This rate is available through Friday, January 27 or until the block sells out. After this date, rooms can be booked on a space available basis at the prevailing rate.

Please note that all official 2023 Demolition Phoenix hotel information will come from NDA Show Management. Please disregard any communications coming from companies such as the Convention Housing Authority, Global Housing, etc. as they are not working in conjunction with NDA. NDA cannot verify the authenticity of such companies or their representations, and will not be able to provide a resolution to issues related to such reservations. Feel free to contact Catherine Prais with NDA via email at exhibit@demolitionassociation.com if you have any questions about the booking of your hotel reservation.

I. REGISTRATION INFORMATION

NDA is pleased to offer online registration for all 2023 Demolition Phoenix exhibitors. Exhibitors receive one complimentary full conference badge and, for exhibitors with booths 400 sq. ft. and larger, complimentary expo only badges will be included on a limited basis based on booth size. Each company has the opportunity to purchase Full Conference and Expo Only passes for additional employees.

DEMOLITION PHOENIX

Where the future begins

Phoenix, AZ

February 22-25, 2023

On or before January 12, 2023, all additional Full Conference Exhibitor Badges can be purchased at the early bird rate for \$850.00 and Expo Only passes for \$250.00. After January 12, 2023, additional Full Conference Badges can be purchased regular rate of \$950/badge (regular rate, January 13, 2023 – February 22, 2023), and after February 22, 2023 badges can be purchased at the onsite rate of \$1,050/badge.

Please note: Expo Only passes do not include social events, each event can be purchased for an additional fee. Expo Only passes do include admittance to the LIVE DEMOLITION Event.

| Booth Size | Comp Expo Only Badges |
|---------------|-----------------------|
| 400 sq. ft. | 2 |
| 500 sq. ft. | 3 |
| 600 sq. ft. | 4 |
| 700 sq. ft. | 5 |
| 800 sq. ft. | 6 |
| 900 sq. ft. | 8 |
| 1000+ sq. ft. | 10 |

If you do not have your registration instructions or password, e-mail the NDA Registration Team at registration@demolitionassociation.com.

J. RULES AND REGULATIONS

Exhibitors are responsible for compliance with all pertinent regulations and codes concerning fire, safety and health, which may be applicable in the Expo during the event. Exhibitors must comply with NDA's Contract Conditions/Rules & Regulations and the IAEE Display Rules and Regulations as included in this kit.

K. NDA EXHIBIT BOOTH PACKAGE

Each exhibitor will be provided with the following benefits per [10' x 10'] space:

- A standard identification sign (7" x 44") indicating company name and booth number
- Eight-foot (8') high back wall drape and three-foot (3') high side rail drape
- Perimeter security guard service during all show hours (24-hours)
- Daily cleaning of the Expo aisles and common area (if your booth requires daily cleaning, please reference the booth cleaning form in this kit)**
- Exhibitor listing and booth number in the Annual Convention Onsite Guide
- One (1) complimentary full conference registration per company (regardless of square footage)
- Pre-Event/Post-Event attendee list of all registered attendees (to include contact, company name, title, mailing address, phone and email for those that opted-in)

****Exhibitors must carpet booth space. Please reference the order form in this kit.**



DEMOLITION PHOENIX

Where the future begins

Phoenix, AZ

February 22-25, 2023

L. AMERICANS WITH DISABILITIES ACT CONFORMANCE

All Exhibitors shall be responsible for compliance with the Americans with Disabilities Act (ADA). The Exhibitor shall hold NDA and its directors, officers, employees, agents or subcontractors harmless from any consequences of exhibiting company's failure in this regard. For more information on the Americans with Disabilities Act and how to make your exhibit accessible to persons with disabilities, please contact:

ADA
Civil Rights Division
U.S. Department of Justice
950 Pennsylvania Avenue, NW
Civil Rights Division
Disability Rights Section - NYAV
Washington, D.C. 20530
Phone: 800.514.0301
Website: www.ada.gov

DEMOLITION PHOENIX

Where the future begins

Phoenix, AZ

February 22-25, 2023

EXHIBITOR SERVICES DIRECTORY

Audio Visual

AV Concepts
Phone: 480-701-0059
exhibitorservices@avconcepts.com

Electrical and Plumbing

Commonwealth Expo Electric
100 North 3rd Street
Phoenix, AZ 85004
expo@commonwealthelectric.com

General Services Contractor

Levy Exposition Services Inc.
14900 Interurban Ave,
Suite 271
Seattle, WA 98168 Phone:
253-437-0031
operations@levyshow.com

Insurance

Rainprotection Insurance
Phone: 800-528-7975
Sales@rainprotection.net

Internet/WIFI

Order online at:
<https://orders.smartcitynetworks.com>
Phone: 888.446.6911

Photography/Videography

Roose Media, LLC
Eric Purdue
Phone: 612-432-8187
eric@roosedmedia.com

NDA Show Management

2001 K Street NW, 3rd Floor North
Washington, DC 20006
Phone: 312-673-4919
exhibit@demolitionassociation.com

Registration

2001 K Street NW, 3rd Floor North
Washington, DC 20006
Phone: 312-673-4993
registration@demolitionassociation.com

Shipments – Advanced Warehouse

Demolition Phoenix
<Exhibiting Company Name>
Booth # ____
Levy Exposition Services, Inc.
c/o Liberty CFS NV, Inc
2021 S 51st Ave
Phoenix, AZ 85043

Shipments – Direct to Show Site

Demolition Phoenix
<Exhibiting Company Name>
Booth # ____
Phoenix Convention Center
c/o Levy Exposition Services, Inc.
100 N 3rd Street
Phoenix, AZ 85004

DEMOLITION PHOENIX

Where the future begins

Phoenix, AZ

February 22-25, 2023

EXHIBITOR CRITICAL DATES & CHECK LIST

Friday, December 9

- All exhibit space must be paid for in full.
- If a cancellation is made after this date there will be no refund.

Friday, January 6

- All exhibitors occupying island booths must submit floor plans and/or prospective drawings with dimensions of their booth to NDA for review to ensure compliance with IAEE's Guidelines for Display Rules and Regulations. Please email your booth drawing to exhibit@demolitionassociation.com.

Thursday, January 12

- Deadline to register at the Exhibitor Full Conference Early Rate (\$850). After this date, rate increases to the Exhibitor Full Conference Regular Rate (\$950).

Wednesday, February 1

- NDA Exhibitor Appointed Contractor (EAC) Form due.

Wednesday, January 18 – Wednesday, February 15

- Advance shipments accepted at the Levy warehouse.
 - To avoid additional after deadline charges, materials must arrive by February 15, 2023

Friday, January 27

- Book your hotel reservations at the Sheraton Phoenix Downtown by this date to receive discounted room rates.

Tuesday, January 31

- AV order form for early bird pricing deadline

Thursday, February 2

- Deadline to order catering to ensure availability of menu items
- Internet discount deadline through Smart City

Tuesday, February 7

- Levy discount deadline
- Electrical and plumbing discount deadline



DEMOLITION PHOENIX

Where the future begins

Phoenix, AZ

February 22-25, 2023

Wednesday, February 8

- Deadline to order lead retrieval services

Thursday, February 16

- Pre-Show Attendee List sent out

Tuesday, February 21

- Equipment move-in by appointment only

Wednesday, February 22

- Show site shipments accepted at the Phoenix Convention Center
- Exhibitor Move-In 8:00am – 5:00pm

Thursday, February 23

- Exhibitor Move-In 8:00am – 5:00pm
- Expo Open 6:30pm – 8:00pm

Friday, February 24

- Expo Open 10:00am – 4:00pm

Saturday, February 25

- Expo Open 10:00am – 1:00pm
- Exhibitor Move-Out 1:00pm – 8:00pm

Sunday, February 26

- Exhibitor Move-Out 8:00am – 12:00pm
 - All carriers must check-in by 9:00am. All materials must be removed by 12:00pm.

Tuesday, March 1

- Post-Show Attendee List sent out

QUESTIONS?

Contact the NDA Show Management Team at exhibit@demolitionassociation.com or 312.673.4919

DEMOLITION PHOENIX

Where the future begins

Phoenix, AZ

February 22-25, 2023

EXHIBITOR HOUSING

Group Rate Deadline: Friday, January 27

NDA has reserved a block of rooms at the Sheraton Phoenix Downtown. To take advantage of these rates, please click on the link below and reserve your room today!

Sheraton Phoenix Downtown

340 North 3rd Street
Phoenix, AZ 85004

Room Rate: \$259.00/night

[Book your reservation online at the Sheraton!](#)

This rate is available through Friday, January 27 2023 or until the block sells out. After this date, rooms can be booked on a space available basis at the prevailing rate.

Please note that all official 2023 Demolition Phoenix hotel information will come from NDA Show Management. Please disregard any communications coming from companies such as the Convention Housing Authority, Global Housing, etc. as they are not working in conjunction with NDA. NDA cannot verify the authenticity of such companies or their representations, and will not be able to provide a resolution to issues related to such reservations. Feel free to contact exhibit@demolitionassociation.com if you have any questions about your hotel reservation.



DEMOLITION PHOENIX

Where the future begins

Phoenix, AZ

February 22-25, 2023

EXHIBITOR REGISTRATION

NDA is pleased to offer online registration for all 2023 Demolition Phoenix exhibitors. Each exhibitor receives One (1) complimentary Full Conference registration. Booths that are 400 sq. ft. or larger also receive complimentary Expo Only passes. Each company has the opportunity to purchase Full Conference and Expo Only passes for additional employees.

On or before January 12, 2023, all additional Full Conference Exhibitor Badges can be purchased at the early bird rate for \$850.00 and Expo Only passes for \$250.00. After January 12, 2023, additional Full Conference Badges can be purchased regular rate of \$950/badge (regular rate, January 13, 2023 – February 22, 2023), and after February 22, 2023 badges can be purchased at the onsite rate of \$1,050/badge.

Please note: Expo Only passes do not include social events, each event can be purchased for an additional fee. Expo Only passes do include admittance to the LIVE DEMOLITION Event.

If you do not have your registration instructions or password, email the NDA Registration Team at registration@demolitionassociation.com.

Click the link below to access the registration site:

<https://nda.users.membersuite.com/events/21d079c0-0078-cdf8-43e4-0b447a89bf5f/details>

To begin your registration, please follow these steps:

1. Click "Register now"
2. This will take you to the Exhibitor Registration Page, click "Register"
3. Choose to either register yourself or register as a group. ***If you plan to register as a group, the allotments must be used at one time. Substitutions may be made.***
4. Select 'Exhibitor Full Convention Registration' or 'Exhibitor Additional Staff Registration'. Once selected, click 'Next'
5. Add registrant's information to register.
6. Provide RSVP information about social events and activities.
7. Review the summary and add the registrations to cart
8. Click "Checkout"
9. Under **"Add a Discount or Promotional Code"** add the applicable code to receive complimentary registration.
10. If necessary, complete payment information.
11. Choose checkout to complete the registration.

If you have any questions regarding registration please feel free to contact our registration team at 312-673-4993 or at registration@demolitionassociation.com.

If you need assistance with your login and password information, please visit <https://www.demolitionassociation.com/Membership/Member-Login-Help>.

Please note:



DEMOLITION PHOENIX

Where the future begins

Phoenix, AZ

February 22-25, 2023

- There will be a \$100 processing fee for all cancellations received on or before Wednesday, February 8, 2023. After that time, there will be no refunds for registrations cancelled after Wednesday, February 8, 2023. Cancellations must be emailed to registration@demolitionassociation.com prior to this date for refunds to be issued. Name substitutions are allowed to transfer a paid registration to another colleague. Registrations cannot be transferred or applied as a credit to a future event. Telephone cancellations are NOT accepted for refunds. Hotel reservations must be cancelled separately
- Once your company has used your complimentary full conference registration badge, you may purchase additional badges at the rates listed above.
- As an Exhibitor, regardless if you have a full conference badge or an expo only badge you will receive exclusive access to the Expo for scheduled move-in and move-out hours.
- Exhibitor registration badges (Full Conference and Expo Only) allow access to the Expo during the following times:

Move-In Hours:

| | |
|------------------------|----------------------------------------|
| Tuesday, February 21 | (Equipment Move-In Only) |
| Wednesday, February 22 | 8:00 a.m. – 5:00 p.m. (All Exhibitors) |
| Thursday, February 23 | 8:00 a.m. – 5:00 p.m. (All Exhibitors) |

Show Hours:

****Exhibitors are required to be at their booths during the following times:***

| | |
|-----------------------|------------------------|
| Thursday, February 23 | 6:30 p.m. – 8:00 p.m. |
| Friday, February 24 | 10:30 a.m. – 4:00 p.m. |
| Saturday, February 25 | 10:00 a.m. – 1:00 p.m. |

Move-Out Hours:

| | |
|-----------------------|------------------------|
| Saturday, February 25 | 1:00 p.m. – 8:00 p.m. |
| Sunday, February 26 | 8:00 a.m. – 12:00 p.m. |

DEMOLITION PHOENIX

Where the future begins

Phoenix, AZ

February 22-25, 2023

NOTICE OF INTENT TO USE EXHIBITOR APPOINTED CONTRACTOR(S)

Please fill out this form ONLY if you plan to use labor other than that provided by the general service contractor, Levy. **Notices are due Friday, January 13, 2023.**

We have contracted with the following firm to install and/or dismantle our exhibit display at 2023 Demolition Phoenix.

EAC COMPANY NAME: _____

CONTACT: _____

ADDRESS: _____

CITY, STATE, ZIP: _____

TELEPHONE: _____ FAX: _____

E-MAIL: _____

It is understood that the above contractor will service and maintain insurance coverage as follows:

- a) Workman's Compensation insurance in the minimum amounts required by the laws of the State of Arizona.
- b) Comprehensive General Liability insurance with minimum combined single limits of \$1,000,000 for bodily injury and/or property damage in any once occurrence.

Such insurance must be maintained in full force during the period when exhibitor appointed contractor is working on the display at **2023 Demolition Phoenix**.

The exhibitor appointed contractor must furnish NDA Show Management with an original certificate of insurance attesting to this coverage. The exhibitor appointed contractor will not be allowed to work at the show until Show Management has received this form and an original certificate of insurance.

EXHIBITING COMPANY: _____

CONTACT: _____ BOOTH NUMBER: _____

AUTHORIZED SIGNATURE: _____

RETURN FORM TO:

NDA Show Management
2001 K Street NW, 3rd Floor North,
Washington, DC 20006
Phone: 312.673.4919

Email: exhibit@demolitionassociation.com



DEMOLITION PHOENIX

Where the future begins

Phoenix, AZ

February 22-25, 2023

Lead Retrieval

Order by February 8 for early pricing

Pre-ordering your package is encouraged. There will be limited availability for orders onsite.

Order your lead retrieval system online here:

<https://events.smithbucklin.com/client/NDA/467>

If you have any questions regarding lead retrieval, please email
itevents@smithbucklin.com.

EXHIBIT CONSTRUCTION GUIDELINES SUMMARY

The Exhibitor's responsibility can be summed up as simply: **"Be a good neighbor!"** All exhibitors are equal regardless of size and should be given an equal opportunity, within reason, to present their product in the most effective manner to the audience.

STANDARD BOOTH

Linear Booths have only one side exposed to an aisle and are generally arranged in a series along a straight line. They are also called "in-line" booths.

Dimensions: Linear Booths are most commonly ten feet (10') wide and ten feet (10') deep, i.e. 10'x10'. A maximum back wall height limitation of height feet (8') is generally specified.

Use of Space: Regardless of the number of Linear Booths utilized, (e.g. 10'x20', 10'x30', 10'x40', etc.) Display materials should be arranged in such a manner so as not to obstruct sight lines of neighboring exhibitors.

The maximum height of eight feet (8') is allowed only in the rear half of the booth space, with a four-foot (4') height restriction imposed on all materials in the remaining space forward to the aisle.

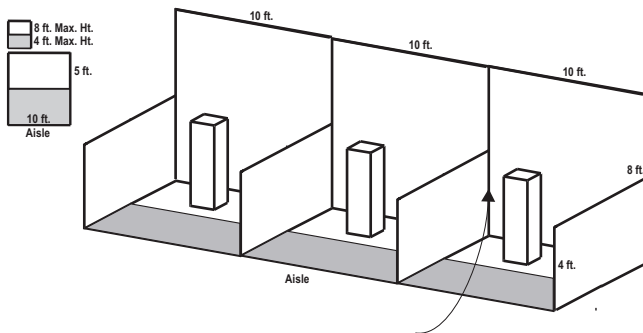

One or more standard 10'x10' units in a straight line.

Note: Booth drape is set at 8 ft max.

Display fixtures over 4 ft high must be confined to that area that is at least 5 ft from the aisle line.

PENINSULA END-CAP BOOTH

An end cap booth is exposed to aisles on three sides and composed of two booths.

Dimensions: End-cap Booths are generally ten feet (10') deep by twenty feet (20') wide. The maximum back wall height of eight feet (8') is allowed only in the rear half of the booth space and within five feet (5') of the two side aisles with a four foot (4') height restriction imposed on all materials in the remaining space forward to the aisle.

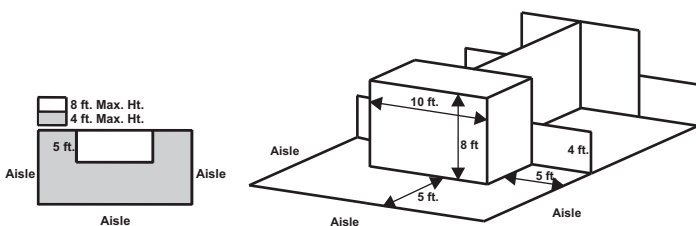

HANGING SIGN BOOTH

An exhibit component suspended above an exhibit of four or more standard units back-to-back with an aisle on at least three sides for the purpose of displaying graphics or identification.

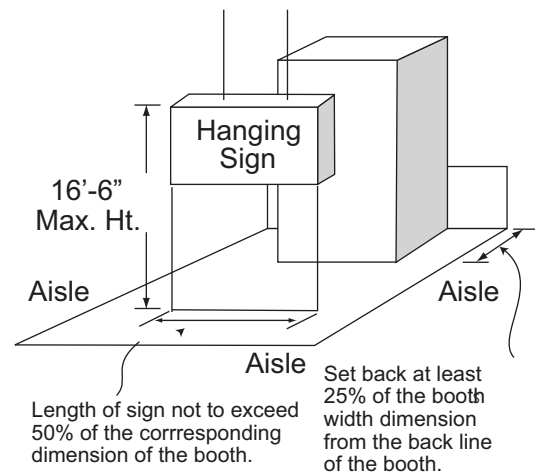

****All overhead hanging must be assembled, installed, and removed by Levy. Please complete the enclosed Labor Order Form for labor to assemble your hanging sign.****

ISLAND BOOTH

An Island Booth is any size booth exposed to aisles on all four sides.

Dimensions: An Island Booth is 20'x30' or larger, although it may be configured differently.

Use of Space: The entire cubic content of the space may be used up to the maximum allowable height, which is usually sixteen feet (16'), including signage.

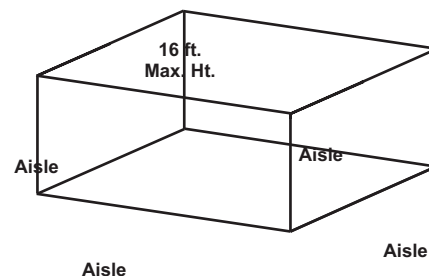

Please note that the ceiling height in the Exhibit Hall is 30 ft.



Fax: 253 437 0032
 14900 Interurban Avenue South, Suite 271
 Seattle, WA
 USA 98168
 Telephone: 253 437 0031
 E-mail: operations@levyexpo.com

DEMOLITION PHOENIX
 February 22 - 25, 2023
 Phoenix Convention Center
 Phoenix, AZ

THIRD PARTY BILLING REQUEST

| | | |
|---------------------------------------------------------------------------|----------------------------------------|----------------------------------------------------------------------------------------------------------------------------------------|
| COMPANY | BOOTH NUMBER | Deadline Date February 1, 2023 |
| ADDRESS <small>street city state/province zip/postal code country</small> | | |
| PHONE <small>FAX</small> | PURCHASE ORDER NUMBER | <i>All orders are regulated by LES Payment Terms & Conditions as well as Material Handling Terms & Conditions.</i> |
| AUTHORIZED CONTACT SIGNATURE X | AUTHORIZED CONTACT - PLEASE PRINT DATE | |

You may arrange for a third party to handle your display and be billed for services. LES will agree to this arrangement if the third party has a satisfactory payment record with us. BOTH firms must complete this form, and the **THIRD PARTY must complete the credit card charge authorization on the *Payment & Credit Card Authorization form***. Return both forms by the deadline date.

It is understood and agreed that the exhibiting firm is ultimately responsible for payment of charges. If your named third party does not pay the invoice before the last day of the show, charges will revert to you, the exhibiting firm. All invoices are due and payable upon receipt.

EXHIBITING FIRM

EXHIBITING FIRM _____

ADDRESS _____

CITY STATE/PROVINCE ZIP/POSTAL CODE _____

PHONE FAX _____

AUTHORIZED SIGNATURE _____

THIRD PARTY

THIRD PARTY _____

ADDRESS _____

CITY STATE/PROVINCE ZIP/POSTAL CODE _____

PHONE FAX _____

AUTHORIZED SIGNATURE _____

ALL LES SERVICES WILL BE INVOICED TO THE THIRD PARTY UNLESS INDICATED BELOW:

EXHIBITING FIRM'S CREDIT CARD CHARGE AUTHORIZATION

CARDHOLDER'S BILLING ADDRESS _____

CITY PROV. / STATE _____

POSTAL/ZIP CODE COUNTRY _____

TODAY'S DATE MONTH / DAY / YEAR

CARD NUMBER

VISA MASTERCARD AMEX CHECK

EXPIRY DATE CVCC

CARDHOLDER NAME (PLEASE PRINT) _____

SIGNATURE _____



Fax: 253 437 0032
 14900 Interurban Avenue South, Suite 271
 Seattle, WA
 USA 98168
 Telephone: 253 437 0031
 E-mail: operations@levyexpo.com

DEMOLITION PHOENIX
 February 22 - 25, 2023
 Phoenix Convention Center
 Phoenix, AZ

PAYMENT & CREDIT CARD CHARGE AUTHORIZATION FORM

| | | | | | | | |
|------------------------------------------|-----|-----------------------------------|--------|----------------|-----------------|----------------------------------------------------------------------------------------------------------------------------|---------|
| COMPANY | | | | BOOTH NUMBER | | All orders are regulated by LES Payment Terms & Conditions as well as Material Handling Terms & Conditions. | |
| ADDRESS | | street | city | state/province | zip/postal code | | country |
| PHONE | FAX | PO # | E-MAIL | | | | |
| AUTHORIZED CONTACT SIGNATURE X | | AUTHORIZED CONTACT - PLEASE PRINT | | DATE | | | |

CREDIT CARD AUTHORIZATION

| | | | | | | | | | | | | | |
|------------------------------------|--|-------------------------------------|--|-------------------------------------------|----------------|-----------------|---------|--|------|--|--|--|-------------------------------------------------------------------------|
| <input type="checkbox"/> VISA | | <input type="checkbox"/> MASTERCARD | | <input type="checkbox"/> AMERICAN EXPRESS | | EXPIRY DATE | | | CCVC | | | | |
| ACCOUNT NUMBER | | | | | | | | | | | | | <input type="checkbox"/> CORPORATE <input type="checkbox"/> PERSONAL |
| CARDHOLDER'S BILLING ADDRESS | | | | city | state/province | zip/postal code | country | | | | | | |
| CARDHOLDER'S SIGNATURE X | | | | CARDHOLDER'S NAME - PLEASE PRINT | | | | | | | | | |

Please complete the REQUIRED order forms and submit with Payment & Credit Card Authorization Form and full payment. You may choose to pay by credit card and/or bank check, however, **we require your credit card authorization to be on file with LES.** For your convenience, we will use this authorization to charge your credit card for any additional amounts incurred as a result of show site orders placed by your representative for this event.

CALCULATION OF ORDER FORMS

TOTAL FROM EACH ORDER FORM

| | | |
|----------------------------------------------------|-----------|--|
| Carpet, Drape & Complements Rental Order Form..... | \$ | |
| Custom Carpet Order Form..... | \$ | |
| Safe Set-up Order Form..... | \$ | |
| Table and Chair Rental Order Form..... | \$ | |
| Specialty Accessories Order Form..... | \$ | |
| Rental Exhibits Order Form..... | \$ | |
| Cabinets Order Form..... | \$ | |
| Graphics & Sign Order Form..... | \$ | |
| Exhibit Booth Cleaning Order Form..... | \$ | |
| Sign & Banner Hanging Order Form..... | \$ | |
| In-Booth Forklift Order Form..... | \$ | |
| Labor Order Form..... | \$ | |
| Material Handling Order Form..... | \$ | |
| Machinery Material Handling Order Form..... | \$ | |
| FULL PAYMENT IN US FUNDS | \$ | |

To simplify payment, send one check payable to Levy Exposition Services Inc. for the entire amount or note the amount to be charged to your credit card.

Charge my credit card in the amount of \$

Check no. Dated in the amount of \$

CARPET and DRAPE

Standard carpet color options



Blue

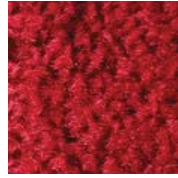

Red

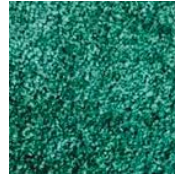

Teal



Grey



Burgundy



Purple



Black

Drape color options



Blue



Red

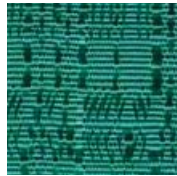

Teal



White

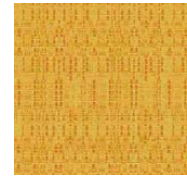

Gold



Black



Purple

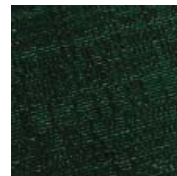

Green



Grey



Burgundy

**DISCLAIMER* Actual products and colors available may vary from the images shown. All products subject to availability*

Do you have questions?

We would be pleased to help. Contact us at: 253 437 0031

operations@levyexpo.com

www.levyexpo.com

CARPET, DRAPE & COMPLEMENTS RENTAL ORDER FORM & INVOICE

COLORED CARPET SELECTIONS

| Description | Discount Rate | Standard Rate | Total |
|----------------------------------------------------------------------------------------------------------------|---------------|---------------|-------|
| Size - 10 ft. X 10 ft. | 252.00 | 327.60 | |
| 10 ft. X 20 ft. | 504.00 | 655.20 | |
| 10 ft. X 30 ft. | 756.00 | 982.80 | |
| 10 ft. X 40 ft. | 1,008.00 | 1,310.40 | |
| Custom cut size. Calculate sq. ft. x price per sq. ft. Size _____ ft. x _____ ft. = _____ sq. ft. | 4.65 | 6.05 | |

Blue Red Teal Grey Burgundy Purple Black

DRAPE (Includes installation and removal)

| | | | |
|---------------------------------|------------|------------|--|
| _____ lin. ft. of 3' high drape | \$8.75/ft | \$11.35/ft | |
| _____ lin. ft. of 8' high drape | \$11.05/ft | \$14.73/ft | |

Blue Red Teal White Gold Black
 Purple Green Grey Burgundy

PLEASE NOTE: THE DRAPE PROVIDED WITH YOUR BOOTH SPACE CANNOT BE CHANGED WITHOUT SHOW MANAGEMENT APPROVAL.

CARPET OPTIONS

| Description | Discount Rate | Standard Rate | Total |
|----------------------------------------------------------------------------------|---------------|---------------|-------|
| Carpet foam padding per sq. ft. Size _____ ft. x _____ ft. = _____ sq. ft. | 2.05 | 2.67 | |
| Poly covering per sq. ft. Size _____ ft. x _____ ft. = _____ sq. ft. | 1.00 | 1.30 | |

COMPLEMENTS (Also see Specialty Accessories Form)

| Quantity | Description | Discount Rate | Standard Rate | Total |
|----------|-------------------------------|---------------|---------------|-------|
| | Waste basket | 27.00 | 35.10 | |
| | Chrome coat tree | 120.00 | 156.00 | |
| | Aluminum easel | 60.00 | 78.00 | |
| | Chrome sign holder 22" X 28" | 140.00 | 182.60 | |
| | Chrome stanchions | 35.00 | 45.50 | |
| | Velvet stanchion ropes - blue | 35.00 | 45.50 | |

SPECIAL INSTRUCTIONS

EXHIBITOR INFORMATION

COMPANY _____

CONTACT _____

BOOTH#

COST SUMMARY

| | | |
|----------------------|-------------------|--|
| RATE ADJUSTMENT | (OFFICE USE ONLY) | |
| 25% CANCELLATION FEE | (OFFICE USE ONLY) | |
| SUBTOTAL | | |
| 8.05% SALES TAX | | |
| TOTAL | US DOLLARS | |

PLEASE REFER TO THE PAYMENT & CREDIT CARD CHARGE AUTHORIZATION FORM

ORDERS WILL NOT BE PROCESSED WITHOUT PAYMENT

STANDARD RATE will be applied to all orders not received and paid in full by **February 1, 2023**. We reserve the right to adjust orders calculated incorrectly.

A 25% CANCELLATION FEE will be applied to all orders received and then canceled. If full service has been provided then 100% of original fee will be applied.

CUSTOM CARPET

Deluxe Decorator 28oz. Carpet color options



Black



Red



Nu Blue



Silver Cloud



Beige



Charcoal



Key Lime

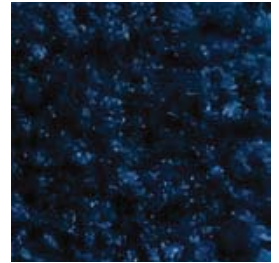

Navy



Cobalt



White

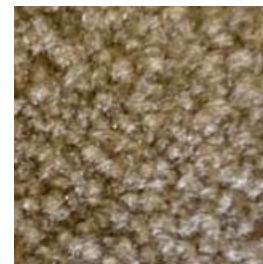

Silky Beige

**DISCLAIMER* Actual products and colors available may vary from the images shown. All products subject to availability*

Do you have questions?

We would be pleased to help. Contact us at: 253 437 0031

operations@levyexpo.com

www.levyexpo.com

CUSTOM CARPET ORDER FORM

Deluxe 28 oz. Carpet in a Variety of Decorator Colors to Enhance Your Exhibit

- | | | |
|---------------------------------------|--------------------------------------|-----------------------------------|
| <input type="checkbox"/> Black | <input type="checkbox"/> Red | <input type="checkbox"/> Nu Blue |
| <input type="checkbox"/> Silver Cloud | <input type="checkbox"/> Beige | <input type="checkbox"/> Charcoal |
| <input type="checkbox"/> Key Lime | <input type="checkbox"/> Navy | <input type="checkbox"/> Cobalt |
| <input type="checkbox"/> White | <input type="checkbox"/> Silky Beige | |

(CHECK BOX OF COLOR DESIRED)
 SAMPLES AVAILABLE UPON REQUEST

Rental includes installation and poly covering for protection and removal.
 Orders must be received by **3 weeks prior to show** to guarantee availability.

| | DISCOUNT PRICE | STANDARD PRICE (late order) |
|-----------------------------------------------------|--------------------|-----------------------------------|
| Booth Size ____ ft. x ____ ft. = ____ sq. Ft. at | \$6.60 per sq. ft. | \$8.58 per sq. ft. =\$ ____ |
| Carpet Pad ____ ft. x ____ ft. = ____ sq. Ft. at | \$2.05 per sq. ft. | \$2.67 per sq. ft. =\$ ____ |

NOTE: Include a floor plan if additional carpet is required to cover steps, skids and display fixtures. A quotation will be forwarded to you before we proceed

SPECIAL INSTRUCTIONS

EXHIBITOR INFORMATION

| | |
|---------|---------------|
| COMPANY | |
| CONTACT | BOOTH# |

COST SUMMARY

| | | |
|-------------------------|-------------------|--|
| RATE ADJUSTMENT | (OFFICE USE ONLY) | |
| CANCELLATION FEE | (OFFICE USE ONLY) | |
| SUBTOTAL | | |
| 8.05% SALES TAX | | |
| TOTAL US DOLLARS | | |

PLEASE REFER TO THE PAYMENT & CREDIT CARD CHARGE AUTHORIZATION FORM

ORDERS WILL NOT BE PROCESSED WITHOUT PAYMENT

STANDARD RATE will be applied to all orders not received and paid in full by **February 1, 2023**. We reserve the right to adjust orders calculated incorrectly.

A 25% CANCELLATION FEE will be applied to all orders received then canceled. If full service has been provided then 100% of original fee will be applied.

SAFE SETUP OPTIONS ORDER FORM & INVOICE



EASY CLEAN BOOTH
 Upgrade your space with our Easy Clean Booth.
 Hard surfaces with PVC panels that can easily be cleaned.
 Custom graphics for branding available as an optional upgrade!



| Description | Qty. | Discount Rate | Standard Rate | Total |
|-----------------------------------------------------------------------------------------------------------------------------------------------------------------------------------------------------------------------------------------------------------------------------------------------------------------------|------|---------------|---------------|-------|
| EASY CLEAN BOOTH includes: - 3m wide x 2.5m high backwall - white - 3m wide x 2.5m high sidewalls - white - 3m wide x 250mm high fascia header **Black text on white background (logo additional) - (1) 1m counter - white with clear acrylic shield **20" x 40" x 40" tall counter + shield | | 3,740.00 | 4,862.00 | |

Please contact us for graphic upgrade information

QUEUE LINE and PPE ACCESSORIES





| Description | Qty. | Discount Rate | Standard Rate | Total |
|-------------------------------------------------------------------------------------------------------------------------------------------------------------------------------------------------------|------|---------------------|---------------|-------|
|  RETRACTABLE STANCHION (max. belt length 6ft) <input type="checkbox"/> Black | | 35.00 (each) | 45.50 (each) | |
|  STANCHION SIGN TOPPER - stanchion and sign not included - contact for signage specs | | 23.00 (each) | 30.00 (each) | |
| PERSONAL PROTECTION EQUIPMENT PACKAGE includes: - Nitrile gloves (x10) - Non-medical 3 layer disposable face masks (x10) - Surface cleaning product - Personal hand sanitizer (x1) | | Contact for pricing | | |

EXHIBITOR INFORMATION

COMPANY _____

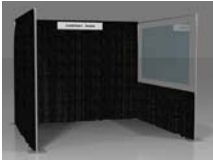

CONTACT _____ **BOOTH#** _____

CLEAR ACRYLIC SHIELD OPTIONS

| Description | Qty. | Discount Rate | Standard Rate | Total |
|-------------------------------------------------------------------------------------------------------------------------------------------------------------------------------------------------------------------------------------------------------------------------------------------------------------------------------------|------|---------------|---------------|-------|
| HANGING CLEAR ACRYLIC SHIELD (For corner drape booths)  - 4' x 8' x 3mm thick clear acrylic sheet - to be hung on 8' high hardware above 3' high drape side wall on open aisle side - includes install and dismantle labour | | 375.00 | 487.50 | |
|  TABLE TOP SNEEZE GUARDS 24" x 8 x 30" **portable unit | | 175.00 | 227.50 | |
|  1m COUNTER with SHIELD Sliding doors & storage shelf 20" x 40" x 40" tall <input type="checkbox"/> Lock (\$21.00 each) <input type="checkbox"/> Graphic panel upgrade (\$280.00) | | 640.00 | 832.00 | |
|  SHIELD on WHEELS 1m wide x 2.5m high frame - 1219mm high x 964mm wide clear acrylic panel **portable unit | | 295.00 | 383.50 | |

SIGNAGE OPTIONS

Display your safety protocols or safe distance reminder message utilizing the below options.

| Description | Qty. | Discount Rate | Standard Rate | Total |
|-----------------------------------------------------------------------------------------------------------------------------------------------------------------------------------------------------|------|-------------------|---------------|-------|
|  CHROME SIGN HOLDER 22" x 28" | | 140.00 | 182.60 | |
|  FLOOR DECALS Suggested size 16" x 16" - install and removal not included Custom size and design | | 49.00 | 64.00 | |
| | | Quoted on Request | | |

COST SUMMARY

| | |
|----------------------------------------|--|
| RATE ADJUSTMENT (OFFICE USE ONLY) | |
| 25% CANCELLATION FEE (OFFICE USE ONLY) | |
| SUBTOTAL | |
| 8.05% SALES TAX | |
| TOTAL US DOLLARS | |

PLEASE REFER TO THE PAYMENT & CREDIT CARD CHARGE AUTHORIZATION FORM
****ORDERS WILL NOT BE PROCESSED WITHOUT PAYMENT****

STANDARD RATE will be applied to all orders not received and paid in full by **February 1, 2023**. We reserve the right to adjust orders calculated incorrectly.

A 25% CANCELLATION FEE will be applied to all orders received and then canceled. If full service has been provided then 100% of original fee will be applied.

TABLES & CHAIRS

Tables

All tables are available in the below options:

- Unskirted or Skirted
- 30" or 40" height
- 4', 6', or 8' lengths x 2' widths



4' x 2' skirted table



6' x 2' skirted table



8' x 2' skirted table

Skirt color options



Blue



Red

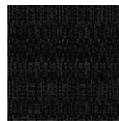

Black



Teal



Burgundy

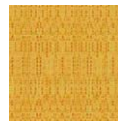

Gold



Green



Grey



Purple



White

Pedestal Tables

All pedestal tables are available in the below options:

- 30" diameter tops
- 30" or 40" high



40" high pedestal



30" high pedestal

Chairs



Fabric Sled Base Chair



Fabric Arm Chair



Fabric Highback Stool

**DISCLAIMER* Actual products and colors available may vary from the images shown. All products subject to availability*

Do you have questions?

We would be pleased to help. Contact us at: 253 437 0031

operations@levyexpo.com

www.levyexpo.com

TABLE AND CHAIR RENTAL ORDER FORM & INVOICE

TABLES



| Description | Qty. | Discount Rate | Standard Rate | Total |
|------------------------------------------------------------------------------------------------------------------------------------------------------------------------------------------------------------------------------------------------------------------------------------------------------------------------|------|---------------|---------------|-------|
|  TABLES 30" HEIGHT | | | | |
| 8' x 2' Skirted | | 250.00 | 325.00 | |
| 6' x 2' Skirted | | 225.00 | 285.00 | |
| 4' x 2' Skirted | | 185.00 | 235.00 | |
| Fourth side of table skirted | | 72.00 | 93.60 | |
| Unskirted table <input type="checkbox"/> 8' <input type="checkbox"/> 6' <input type="checkbox"/> 4' | | 88.00 | 114.40 | |
| <input type="checkbox"/> Blue <input type="checkbox"/> Red <input type="checkbox"/> Black <input type="checkbox"/> Teal <input type="checkbox"/> Burgundy <input type="checkbox"/> Gold <input type="checkbox"/> Green <input type="checkbox"/> Grey <input type="checkbox"/> Purple <input type="checkbox"/> White | | | | |

| Description | Qty. | Discount Rate | Standard Rate | Total |
|------------------------------------------------------------------------------------------------------------------------------------------------------------------------------------------------------------------------------------------------------------------------------------------------------------------------|------|---------------|---------------|-------|
|  TABLES 40" COUNTER HEIGHT | | | | |
| 8' x 2' Skirted | | 285.00 | 345.00 | |
| 6' x 2' Skirted | | 265.00 | 320.00 | |
| 4' x 2' Skirted | | 245.00 | 305.00 | |
| Fourth side of table skirted | | 78.00 | 104.40 | |
| Unskirted table <input type="checkbox"/> 8' <input type="checkbox"/> 6' <input type="checkbox"/> 4' | | 98.00 | 127.40 | |
| <input type="checkbox"/> Blue <input type="checkbox"/> Red <input type="checkbox"/> Black <input type="checkbox"/> Teal <input type="checkbox"/> Burgundy <input type="checkbox"/> Gold <input type="checkbox"/> Green <input type="checkbox"/> Grey <input type="checkbox"/> Purple <input type="checkbox"/> White | | | | |

| Description | Qty. | Discount Rate | Standard Rate | Total |
|-------------------------------------------------------------------------------------------------------------------------------|------|---------------|---------------|-------|
|  GREY PEDESTAL TABLE - 30" DIAMETER | | | | |
| 30" Table height | | 179.00 | 232.70 | |
| 40" Counter height | | 219.00 | 284.70 | |

SPECIAL INSTRUCTIONS

CHAIRS

| Description | Qty. | Discount Rate | Standard Rate | Total |
|---------------------------------------------------------------------------------------------------------------------------|------|---------------|---------------|-------|
|  FABRIC SLED BASE CHAIR - GREY | | 135.00 | 165.00 | |
|  FABRIC SLED BASE ARMCHAIR - GREY | | 145.00 | 175.00 | |
|  FABRIC HIGHBACK STOOL - GREY | | 185.00 | 220.00 | |

EXHIBITOR INFORMATION

COMPANY _____

CONTACT _____ **BOOTH#** _____

| COST SUMMARY | | |
|-------------------------|-------------------|--|
| RATE ADJUSTMENT | (OFFICE USE ONLY) | |
| CANCELLATION FEE | (OFFICE USE ONLY) | |
| SUBTOTAL | | |
| 8.05% SALES TAX | | |
| TOTAL US DOLLARS | | |





PLEASE REFER TO THE PAYMENT & CREDIT CARD CHARGE AUTHORIZATION FORM
****ORDERS WILL NOT BE PROCESSED WITHOUT PAYMENT****

STANDARD RATE will be applied to all orders not received and paid in full by **February 1, 2023**. We reserve the right to adjust orders calculated incorrectly.



A 25% CANCELLATION FEE will be applied to all orders received and then canceled. If full service has been provided then 100% of original fee will be applied.

SPECIALTY ACCESSORIES RENTAL ORDER FORM & INVOICE

DISPLAY UNITS

| Description | Qty. | Discount Rate | Standard Rate | Total |
|-------------------------------------------------------------------------------------------------------------------------------------------------------------------------------------------------------------------------------------------|------|---------------|---------------|-------|
|  FABRIC POSTER BOARD 4' x 8' grey fabric covered both sides <input type="checkbox"/> Horizontal (shown) <input type="checkbox"/> Vertical | | 144.00 | 187.00 | |
|  BLACK UPRIGHT LITERATURE RACK 6 pockets for 8.5" x 11" material | | 160.00 | 208.00 | |
|  PLEXIGLASS BROCHURE HOLDER 9" x 11" <input type="checkbox"/> Table top <input type="checkbox"/> Wall mount | | 46.00 | 59.80 | |
|  ALUMINUM EASEL Fits sign sizes: 22" x 28" 24" x 36" 28" x 44" | | 60.00 | 78.00 | |
|  CHROME SIGN HOLDER 22" x 28" | | 140.00 | 182.60 | |

ACCESSORIES

| | | | | |
|--------------------------------------------------------------------------------------------------------------------------------------------------------------------------------|--|--------|--------|--|
|  <input type="checkbox"/> CHROME CLOTHING STAND <input type="checkbox"/> CHROME BAG HOLDER | | 120.00 | 156.00 | |
|  CHROME COAT TREE | | 120.00 | 156.00 | |

SPECIAL INSTRUCTIONS

EXHIBITOR INFORMATION

COMPANY

CONTACT

BOOTH#

COST SUMMARY

| | | |
|----------------------|-------------------|--|
| RATE ADJUSTMENT | (OFFICE USE ONLY) | |
| 25% CANCELLATION FEE | (OFFICE USE ONLY) | |
| SUBTOTAL | | |
| 8.05% SALES TAX | | |
| TOTAL | US DOLLARS | |

PLEASE REFER TO THE PAYMENT & CREDIT CARD CHARGE AUTHORIZATION FORM

ORDERS WILL NOT BE PROCESSED WITHOUT PAYMENT

STANDARD RATE will be applied to all orders not received and paid in full by **February 1, 2023**. We reserve the right to adjust orders calculated incorrectly.

A 25% CANCELLATION FEE will be applied to all orders received and then canceled. If full service has been provided then 100% of original fee will be applied.

RENTAL EXHIBITS

10' x 10' Hardwall Rental Exhibit Booths

All hardwall packages include the below:

- Aluminum structure
- White
- Header(s) - block letters - black (logo extra)
- 10' x 10' Carpet
- 30" pedestal table (x1)
- Fabric sledbase chairs (x2)

Package A1 Base



Package A2 Deluxe

- Base Package plus the below:
- 10" deep shelves (x2)
- 39" x 20" x 39" counter (x1)

Package B1 Base

- Curved header - block letters - black (logo extra)
- Curved front display counter



Package B2 Deluxe

- Base Package plus the below:
- Enclosed corner counter
- 10" deep shelves (x2)

Package C1 Base



Package C2 Deluxe

- Base Package plus the below:
- 10" deep shelves (x2)
- 39" x 20" x 39" counter (x1)

Package D1 Base

- Oversized header - block letters - black (logo extra)
- 20" x 39" x 39" high built-in counters on backwall (x2)



Package D2 Deluxe

- Base Package plus the below:
- 10" deep shelves (x2)
- 39" x 20" x 39" counter (x1)

**DISCLAIMER* Actual products and colors available may vary from the images shown. All products subject to availability*

Do you have questions?

We would be pleased to help. Contact us at: 253 437 0031

operations@levyexpo.com

www.levyexpo.com

RENTAL EXHIBITS

10' x 20' Hardwall Rental Exhibit Booths

All hardwall packages include the below:

- Aluminum structure
- White
- Header(s) - block letters - black (logo extra)
- 10' x 20' Carpet
- 30" pedestal table (x1)
- Fabric sledbase chairs (x2)

Package E1 Base

- Straight headers (x2)



Package E2 Deluxe

- Base Package plus the below:
- 10" deep shelves (x2)
- 39" x 20" x 39" counter (x1)

Package F1 Base

- Straight header (x1)
- Angled header (x2)
- Storage area with drape door
- Front built-in corner counters (x2)



Package F2 Deluxe

- Base Package plus the below:
- Lockable door for storage area
- 39" x 20" x 39" counter (x2)

Package G1 Base

- Straight header (x1)
- 39" x 20" x 39" built-in counter (x1)



Package G2 Deluxe

- Base Package plus the below:
- 10" deep shelves (x4)

Package H1 Base

- Oversized curved header (x1)
- 39" x 20" x 39" built-in counters (x3)



Package H2 Deluxe

- Base Package plus the below:
- 10" deep shelves (x3)
- 2m curved front counter (x1)

**DISCLAIMER* Actual products and colors available may vary from the images shown. All products subject to availability*

Do you have questions?

We would be pleased to help. Contact us at: 252 437 0031

operations@levyexpo.com

www.levyexpo.com

CUSTOM EXHIBITS

A more sophisticated technique to exhibit marketing messages creatively and effectively!

With decades of service, Levy continues to provide viable and reliable alternatives to maximize clients' overall booth space. Our sales team and design specialists work closely with each and every client to create a unique exhibit designed to meet a wide variety of today's marketing strategies. Whether the image and budget are conservative or extravagant Levy exceeds to offer the most suitable and perfect space solutions.



Collaboratively designed to meet your specific requirements, budget, and bring your vision to reality.

Each Levy Custom Designed Exhibit will be built to exact specifications and will be:

- Unique
- Attractive
- Versatile
- Impressive
- Memorable
- Functional
- Creative
- Inviting
- Efficient

Let us help you create a one of a kind booth space.

Call our experienced professionals for an innovative, customized, and no obligation approach.

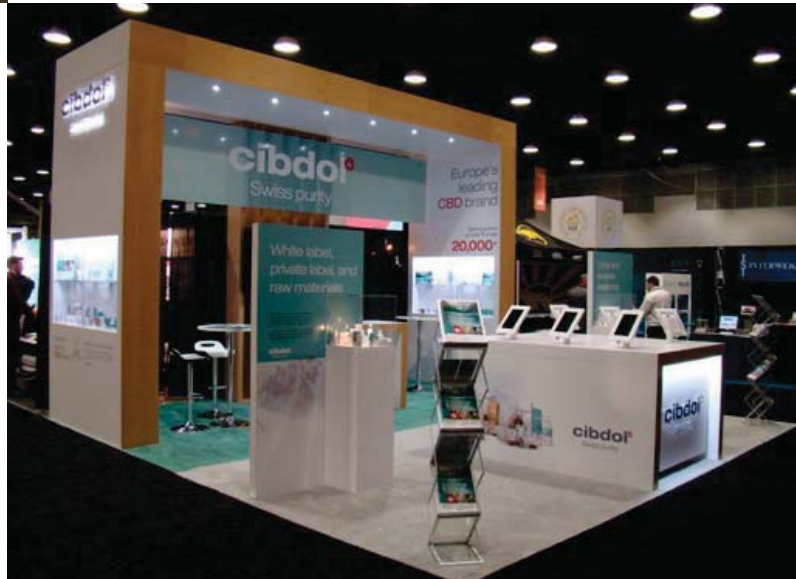



Fax: 253 437 0032
 14900 Interurban Avenue South, Suite 271
 Seattle, WA
 USA 98168
 Telephone: 253 437 0031
 E-mail: operations@levyexpo.com

DEMOLITION PHOENIX
 February 22 - 25, 2023
 Phoenix Convention Center
 Phoenix, AZ

RENTAL EXHIBITS RENTAL ORDER FORM & INVOICE

10' x 10' BOOTH PACKAGES - Please contact customer service for GRAPHIC UPGRADES

| Description | Qty | Discount Rate | Standard Rate | Total |
|---------------------------------------------------------------------------------------------------------------------------------------------------------------------------------------------------------------|-----|---------------|---------------|-------|
| Description: Base package includes: Aluminum structure, white hardwalls, booth header with company name in block lettering, carpet, 30" pedestal table, (2) fabric chairs, installation and dismantle. | | | | |
| PACKAGE A1 Basic - Base package with header | | 3,240.00 | 4,212.00 | |
| PACKAGE A2 Deluxe - Base package + (2) 10" deep shelves, (1) 39" x 20" x 39" counter | | 3,682.00 | 4,786.00 | |
| PACKAGE B1 Basic - Corner base package booth with curved counter, 1 curved header sign | | 3,690.00 | 4,797.00 | |
| PACKAGE B2 Deluxe - Base package + enclosed corner counter, (2) 10" deep shelves | | 3,740.00 | 4,862.00 | |
| PACKAGE C1 Basic - Base package with header | | 3,390.00 | 4,407.00 | |
| PACKAGE C2 Deluxe - Base package + (2) 10" deep shelves, (1) 39" x 20" x 39" counter | | 3,832.00 | 4,981.00 | |
| PACKAGE D1 Basic - Base package with oversized header, (2) built-in back counters | | 3,820.00 | 4,966.00 | |
| PACKAGE D2 Deluxe - Base package + (2) 10" deep shelves, (1) 39" x 20" x 39" counter | | 4,262.00 | 5,540.00 | |

10' x 20' BOOTH PACKAGES - Please contact customer service for GRAPHIC UPGRADES

| Description | Qty | Discount Rate | Standard Rate | Total |
|---------------------------------------------------------------------------------------------------------------------------------------------------------------------------------------------------------------|-----|---------------|---------------|-------|
| Description: Base package includes: Aluminum structure, white hardwalls, booth header with company name in block lettering, carpet, 30" pedestal table, (2) fabric chairs, installation and dismantle. | | | | |
| PACKAGE E1 Basic - Base package with headers | | 4,860.00 | 6,318.00 | |
| PACKAGE E2 Deluxe - Base package + (2) 10" deep shelves, (1) 39" x 20" x 39" counter | | 5,302.00 | 6,892.00 | |
| PACKAGE F1 Basic - Base package with headers, storage and drape door, (2) built-in counters | | 5,210.00 | 6,773.00 | |
| PACKAGE F2 Deluxe - Base package + lockable door for storage, (2) 39" x 20" x 39" counters | | 5,652.00 | 7,347.00 | |
| PACKAGE G1 Basic - Base package with header, (1) built-in counter | | 5,520.00 | 7,176.00 | |
| PACKAGE G2 Deluxe - Base package + (2) 10" deep shelves | | 5,962.00 | 7,751.00 | |
| PACKAGE H1 Basic - Base package with oversized curved header, (3) built-in back counters | | 6,180.00 | 8,034.00 | |
| PACKAGE H2 Deluxe - Base package + (2) 10" deep shelves, (1) curved front counter | | 6,622.00 | 8,608.00 | |

OPTIONS & INFORMATION

HARDWALL PANEL (non fabric) SELECTION

White

CARPET COLOR SELECTIONS

Grey Red Teal Blue Black Burgundy Purple

HEADER TO READ (up to 20 characters, black lettering on white)

Header One

Header Two

ACCESSORY OPTIONS

| Description | Qty. | Discount Rate | Standard Rate | Total |
|--------------------------------------------------------------------------------------------|------|------------------|----------------|-------|
| 1 meter Angled Shelves | | 58.00 | 75.40 | |
| 1 meter Shelves | | 49.00 | 63.70 | |
| Spot Lights (For use with rental unit) | | 64.00 | 83.20 | |
| Literature Pockets 8 1/2" x 11" | | 26.00 | 33.80 | |
| Nylon Loop Fabric Panel per sq.ft. <small>**contact for available color options</small> | | \$4.25 sq.ft. | 5.53 sq.ft. | |

SPECIAL INSTRUCTIONS

EXHIBITOR INFORMATION

COMPANY

CONTACT

BOOTH#

COST SUMMARY

| | | |
|----------------------|-------------------|--|
| RATE ADJUSTMENT | (OFFICE USE ONLY) | |
| 25% CANCELLATION FEE | (OFFICE USE ONLY) | |
| SUBTOTAL | | |
| 8.05% SALES TAX | | |
| TOTAL | US DOLLARS | |

PLEASE REFER TO THE PAYMENT & CREDIT CARD CHARGE AUTHORIZATION FORM

ORDERS WILL NOT BE PROCESSED WITHOUT PAYMENT

STANDARD RATE will be applied to all orders not received and paid in full by **February 1, 2023**. We reserve the right to adjust orders calculated incorrectly.

A 25% CANCELLATION FEE will be applied to all orders received and then cancelled 2 weeks prior to install. If full service has been provided then 100% of original fee will be applied.
 xpo21_rentalexhibits

CABINETS

Straight Cabinets

All straight cabinets come with sliding doors. Optional Upgrades noted below:

- Lock for doors
- Lighting
*Jewelry Case or Show Case
- Branding - graphic panels



Cabinet "A"

1 meter cabinet with doors
39" long x 20" deep x 40" high



Cabinet "B"

1 meter Jewelry Case with doors
39" long x 20" deep x 40" high



Cabinet "C"

1 meter Show Case with doors
39" long x 20" deep x 40" high



Cabinet "D"

2 meter cabinet with doors
80" long x 20" deep x 40" high

Curved Cabinets

Optional Upgrades noted below:

- Lock for doors
- Branding - graphic panels



Cabinet "E"

1 meter curved cabinet
61" long x 20" deep x 40" high

Cabinet "F"

1 meter curved cabinet with door
61" long x 20" deep x 40" high

**Same as cabinet "E" but with door

**DISCLAIMER* Actual products and colors available may vary from the images shown. All products subject to availability*

CABINETS ORDER FORM & INVOICE

| STYLE | DESCRIPTION | QTY | DISCOUNT RATE | STANDARD RATE | TOTAL |
|-------------|------------------------------------------------------------------------------------------------------------------------------------|-----|---------------|---------------|-------|
| CABINET "A" | 1 meter Cabinet with doors <input type="checkbox"/> Lock (\$20.00 each) | | 580.00 | 754.00 | |
| | Cabinet with + custom graphic panel <input type="checkbox"/> Lock (\$20.00 each) | | 755.00 | 981.50 | |
| CABINET "B" | 1 meter Jewelry Case with doors <input type="checkbox"/> Lock (\$20.00 each) <input type="checkbox"/> Lights (\$20.00 each) | | 660.00 | 858.00 | |
| | Jewelry Case + custom graphic panel <input type="checkbox"/> Lock (\$20.00 each) <input type="checkbox"/> Lights (\$20.00 each) | | 774.00 | 1,026.20 | |
| CABINET "C" | 1 meter Show Case with doors <input type="checkbox"/> Lock (\$20.00 each) <input type="checkbox"/> Lights (\$20.00 each) | | 760.00 | 988.00 | |
| | Show Case + custom graphic panel <input type="checkbox"/> Lock (\$20.00 each) <input type="checkbox"/> Lights (\$20.00 each) | | 830.00 | 1,079.00 | |
| CABINET "D" | 2 meter Cabinet with doors <input type="checkbox"/> Lock (\$20.00 each) | | 780.00 | 1,014.00 | |
| | 2 meter Cabinet + custom graphic panel <input type="checkbox"/> Lock (\$20.00 each) | | 1,151.00 | 1,496.30 | |
| CABINET "E" | 1 meter Curved cabinet (open back) | | 670.00 | 871.00 | |
| | Curved cabinet + custom graphic panel | | 955.00 | 1,241.50 | |
| CABINET "F" | 1 meter Curved cabinet with doors <input type="checkbox"/> Lock (\$20.00 each) | | 690.00 | 897.00 | |
| | Curved cabinet w/ doors + custom graphic panel | | 975.00 | 1,267.50 | |

NOTE: Should you wish to have a graphic panel upgrade for your cabinet, please contact our Operations department to confirm details on graphic file submission.

| EXHIBITOR INFORMATION | |
|-----------------------|---------------|
| COMPANY | |
| CONTACT | BOOTH# |

| COST SUMMARY | | |
|-------------------------|-------------------|--|
| RATE ADJUSTMENT | (OFFICE USE ONLY) | |
| CANCELLATION FEE | (OFFICE USE ONLY) | |
| SUBTOTAL | | |
| 8.05% SALES TAX | | |
| TOTAL US DOLLARS | | |

PLEASE REFER TO THE PAYMENT & CREDIT CARD CHARGE AUTHORIZATION FORM
 ORDERS WILL NOT BE PROCESSED WITHOUT PAYMENT

STANDARD RATE will be applied to all orders not received and paid in full by **February 1, 2023**. We reserve the right to adjust orders calculated incorrectly.

A 25% CANCELLATION FEE will be applied to all orders received and then cancelled. If full service has been provided then 100% of original fee will be applied.

GRAPHICS AND SIGN ORDER FORM & INVOICE

STANDARD SIGN SIZES

| Quantity | Description | Discount Rate | Standard Rate | Total |
|----------|-------------|---------------|---------------|-------|
| | 7" x 11" | 31.00 | 40.00 | |
| | 7" x 44" | 37.00 | 48.00 | |
| | 11" x 14" | 47.00 | 61.00 | |
| | 14" x 22" | 63.00 | 82.00 | |
| | 22" x 28" | 79.00 | 103.00 | |
| | 28" x 44" | 113.00 | 147.00 | |

Prices listed are for one-color copy (up to 10 words) on a white background.

OPTIONAL SERVICES

| Quantity | Description | Discount Rate | Standard Rate | Total |
|----------|--------------------------------------|-------------------|---------------|-------|
| | Over 10 words (Add per word) | 3.62 | 4.70 | |
| | Easel back on sign (Up to 22" x 28") | 4.83 | 6.23 | |
| | Logo sign | Quoted on Request | | |
| | Banner | Quoted on Request | | |

DIGITAL GRAPHICS (6 SQ FT MINIMUM)

- Digital files must be provided to LES specifications.
- Graphics should be sent in vector format as .eps files.
Also acceptable: Adobe Illustrator (.ai) & Corel Draw (.cdr) files
- Photographic & Pixel based complex graphics must be MINIMUM 100 dpi at actual output size.
Acceptable formats include: .tif, .bmp, & Adobe Photoshop & Corel Photo Paint files
- All text **MUST** be outlined / converted to curves, or fonts included with image files.
- Art work is to be received as file ready.
- Editing & Design time is charged at a rate of \$75.00 per hour (1 hour minimum).
- Digital files must be received at least three (3) weeks before show to receive discount price.

| Quantity | Description | Discount Rate | Standard Rate | Total |
|----------|-----------------------------------------------------------------------|---------------|---------------|-------|
| | Digital Prints per sq.ft. (Mounted on Foamcore w/ Matte Laminates) | \$19.50 | \$29.00 | |

EXHIBITOR INFORMATION

COMPANY

CONTACT

BOOTH#

INDICATE YOUR SIGN COPY HERE

ADDITIONAL SERVICES & TERMS

If you would like us to provide more information and pricing on banners, logos, silk screening, special graphics or any other items please contact our Exhibits department for a complimentary consultation.

Orders required within 72 hours before show opening may be subject to a rush delivery charge. Please allow a minimum of 24 hours for any on-site sign orders.

CHOOSE YOUR LAYOUT

 Vertical

 Horizontal

Levy Exposition Services Inc.
to design layout

LETTER COLOR SELECTIONS

- Blue Red Green Teal Black Purple
 Black lettering will be provided unless otherwise specified.

SPECIAL INSTRUCTIONS

COST SUMMARY

| | | |
|-----------------------|-------------------|--|
| RATE ADJUSTMENT | (OFFICE USE ONLY) | |
| 100% CANCELLATION FEE | (OFFICE USE ONLY) | |
| SUBTOTAL | | |
| 8.05% SALES TAX | | |
| TOTAL | US DOLLARS | |

PLEASE REFER TO THE PAYMENT & CREDIT CARD CHARGE AUTHORIZATION FORM

****ORDERS WILL NOT BE PROCESSED WITHOUT PAYMENT****

STANDARD RATE will be applied to all orders not received and paid in full by **February 1, 2023**. We reserve the right to adjust orders calculated incorrectly.

A 100% CANCELLATION FEE will be applied to all orders received then cancelled.



Fax: 253 437 0032
 14900 Interurban Avenue South, Suite 271
 Seattle, WA
 USA 98168
 Telephone: 253 437 0031
 E-mail: operations@levyexpo.com

DEMOLITION PHOENIX
 February 22 - 25, 2023
 Phoenix Convention Center
 Phoenix, AZ

PLANT & FLOWER RENTAL ORDER FORM & INVOICE

LIVE PLANTS

| Quantity | Description | Discount Rate | Standard Rate | Total |
|----------|---------------------|---------------|---------------|-------|
| | Potted flowers | 58.00 | 75.40 | |
| | Boston fern | 64.00 | 83.20 | |
| | Hanging green plant | 64.00 | 83.20 | |

LIVE TROPICAL PLANTS

| Quantity | Description | Discount Rate | Standard Rate | Total |
|----------|--------------------------|---------------|---------------|-------|
| | 3' - 4' tall floor plant | 92.00 | 119.20 | |
| | 4' - 5' tall floor plant | 109.00 | 141.70 | |
| | 6' tall floor plant | 134.00 | 174.20 | |

COLORFUL FRESH CUT FLOWERS

| Quantity | Description | Discount Rate | Standard Rate | Total |
|----------|--------------------------|---------------|---------------|-------|
| | Small floral arrangement | 178.00 | 231.40 | |
| | Large floral arrangement | 240.00 | 312.00 | |

Please indicate color preference here, if any: _____

The above items are priced on a rental basis only. Price includes container, delivery, installation and removal at the end of show. Any items missing from the booth upon dismantling are the responsibility of the exhibitor and an additional charge will be applied.

SPECIAL INSTRUCTIONS

EXHIBITOR INFORMATION

COMPANY _____

CONTACT _____ BOOTH#

COST SUMMARY

| | | |
|----------------------|-------------------|--|
| RATE ADJUSTMENT | (OFFICE USE ONLY) | |
| 25% CANCELLATION FEE | (OFFICE USE ONLY) | |
| SUBTOTAL | | |
| 8.05% SALES TAX | | |
| TOTAL | US DOLLARS | |

PLEASE REFER TO THE PAYMENT & CREDIT CARD CHARGE AUTHORIZATION FORM
 ORDERS WILL NOT BE PROCESSED WITHOUT PAYMENT

STANDARD RATE will be applied to all orders not received and paid in full by **February 1, 2023**. We reserve the right to adjust orders calculated incorrectly.

A 25% CANCELLATION FEE will be applied to all orders received then canceled. If full service has been provided then 100% of original fee will be applied.



Fax: 253 437 0032
 14900 Interurban Avenue South, Suite 271
 Seattle, WA
 USA 98168
 Telephone: 253 437 0031
 E-mail: operations@levyexpo.com

DEMOLITION PHOENIX
 February 22 - 25, 2023
 Phoenix Convention Center
 Phoenix, AZ

EXHIBIT BOOTH CLEANING ORDER FORM & INVOICE

SERVICES

OUR SERVICES INCLUDE THE FOLLOWING:

EXHIBIT VACUUMING EMPTYING OF WASTEBASKETS GENERAL HOUSEKEEPING

DISCOUNT RATE

| TOTAL SQUARE FEET OF BOOTH SPACE | DAYS REQUIRED | RATE | TOTAL |
|----------------------------------|-------------------------------------------------------------------------------------------------------------------------------------------------------------------------------|------------|-------|
| | <input type="checkbox"/> Prior To Show Opening <input type="checkbox"/> After First Day <input type="checkbox"/> After Second Day <input type="checkbox"/> After Third Day | | |
| _____ | X _____ | X \$0.82 = | _____ |
| 100 Square Feet Minimum Order | Total Number of Days | | |

STANDARD RATE & ON-SITE ORDERS

| TOTAL SQUARE FEET OF BOOTH SPACE | DAYS REQUIRED | RATE | TOTAL |
|----------------------------------|-------------------------------------------------------------------------------------------------------------------------------------------------------------------------------|------------|-------|
| | <input type="checkbox"/> Prior To Show Opening <input type="checkbox"/> After First Day <input type="checkbox"/> After Second Day <input type="checkbox"/> After Third Day | | |
| _____ | X _____ | X \$0.95 = | _____ |
| 100 Square Feet Minimum Order | Total Number of Days | | |

ADDITIONAL INFORMATION

General vacuuming of the show floor aisles is provided, however, cleaning of your exhibit area is not included in your exhibit space rental.

If you have any questions or need assistance with any items not listed, please contact our exhibits department.

All carpets ordered from us are installed clean for your use. However, you may order cleaning services for debris created during set-up and show hours.

A surcharge may be applied for any damage and or staining of exhibit space.

SPECIAL INSTRUCTIONS

Please indicate on the lines below any special cleaning requests or instructions you may have.

EXHIBITOR INFORMATION

COMPANY _____

CONTACT _____ **BOOTH#** _____

COST SUMMARY

| | | |
|----------------------|-------------------|--|
| RATE ADJUSTMENT | (OFFICE USE ONLY) | |
| 25% CANCELLATION FEE | (OFFICE USE ONLY) | |
| SUBTOTAL | | |
| | | |
| TOTAL | US DOLLARS | |

PLEASE REFER TO THE PAYMENT & CREDIT CARD CHARGE AUTHORIZATION FORM
 ORDERS WILL NOT BE PROCESSED WITHOUT PAYMENT

STANDARD RATE will be applied to all orders not received and paid in full by **February 1, 2023**. We reserve the right to adjust orders calculated incorrectly.

A 25% CANCELLATION FEE will be applied to all orders received then canceled. If full service has been provided then 100% of original fee will be applied.



Fax: 253 437 0032
 14900 Interurban Avenue South, Suite 271
 Seattle, WA
 USA 98168
 Telephone: 253 437 0031
 E-mail: operations@levyexpo.com

DEMOLITION PHOENIX
February 22 - 25, 2023
Phoenix Convention Center
Phoenix, AZ

IN-BOOTH FORKLIFT ORDER FORM & INVOICE

TERMS & CONDITIONS

The exhibitor, his agent or representative must supply sufficient manpower including competent and authorized supervisors to manage and control the exhibit installation activity.

The exhibitor, upon signing this order form, covenants and agrees to indemnify and hold harmless Levy Exposition Services Inc., from and against all claims, demands, charges, losses or damage arising or alleged to arise directly or indirectly or incidentally by person of any act omission or operations of the exhibitor, his agent or representative, their officers, employees, agents or anyone for whom the exhibitor, his agent or representative are legally responsible. Levy Exposition Services Inc., is to be cross insured on the insurance for the exhibitor's, his agent's or representative's operations conducted at this event. Evidence of the insurance described above shall be forwarded to Levy Exposition Services Inc.

THIS SERVICE IS NOT PROVIDED BY SHOW MANAGEMENT

RATES

| DESCRIPTION | STANDARD RATE | |
|----------------------------------------------------------------------------------------------------------------------------------------|-------------------|--|
| STRAIGHT TIME 8:00 AM - 4:30 PM Monday to Friday (Includes 5000 lb. Forklift and operator) | \$260.00 per Hour | |
| STRAIGHT TIME 8:00 AM - 4:30 PM Monday to Friday (Foreman) | \$150.00 per Hour | |
| OVERTIME 4:30 PM - 8:00 AM Monday to Friday, (Includes 5000 lb Forklift and operator) All day Saturday, Sunday, and holidays | \$380.00 per Hour | |
| OVERTIME 4:30 PM - 8:00 AM Monday to Friday, (Foreman) All day Saturday, Sunday, and holidays | \$215.00 per Hour | |

ESTIMATED INSTALLATION REQUIREMENTS

| DESCRIPTION | STANDARD RATE | TOTAL | There is a minimum charge of one (1) hour per forklift. Additional time thereafter is charged in one-half (1/2) hour increments. Date Required _____ Start Time _____ |
|-------------------------------------------------|-------------------|---------------|---------------------------------------------------------------------------------------------------------------------------------------------------------------------------------|
| STRAIGHT TIME _____ Forklift _____ Hours | \$260.00 per Hour | \$_____ Total | |
| OVERTIME _____ Forklift _____ Hours | \$380.00 per Hour | \$_____ Total | |

ESTIMATED DISMANTLE REQUIREMENTS

| DESCRIPTION | STANDARD RATE | TOTAL | There is a minimum charge of one (1) hour per forklift. Additional time thereafter is charged in one-half (1/2) hour increments. Date Required _____ Start Time _____ |
|-------------------------------------------------|-------------------|---------------|---------------------------------------------------------------------------------------------------------------------------------------------------------------------------------|
| STRAIGHT TIME _____ Forklift _____ Hours | \$260.00 per Hour | \$_____ Total | |
| OVERTIME _____ Forklift _____ Hours | \$380.00 per Hour | \$_____ Total | |

EXHIBITOR INFORMATION

COMPANY _____

CONTACT _____ **BOOTH#** _____

***PLEASE ADD 25% FOR ORDERS PLACED AFTER FEBRUARY 1, 2023.**

COST SUMMARY

| | | |
|---------------------------|-------------------|--|
| RATE ADJUSTMENT | (OFFICE USE ONLY) | |
| 25% CANCELLATION FEE | (OFFICE USE ONLY) | |
| SUBTOTAL | | |
| ADDITIONAL 25% LATE ORDER | | |
| TOTAL | US DOLLARS | |

PLEASE REFER TO THE PAYMENT & CREDIT CARD CHARGE AUTHORIZATION FORM

ORDERS WILL NOT BE PROCESSED WITHOUT PAYMENT

A 25% CANCELLATION FEE will be applied to all orders received then canceled. If full service has been provided then 100% of original fee will be applied.



Fax: 253 437 0032
 14900 Interurban Avenue South, Suite 271
 Seattle, WA
 USA 98168
 Telephone: 253 437 0031
 E-mail: operations@levyexpo.com

DEMOLITION PHOENIX
February 22 - 25, 2023
 Phoenix Convention Center
 Phoenix, AZ

SIGN & BANNER HANGING ORDER FORM & INVOICE

TERMS AND CONDITIONS

ALL OVERHEAD HANGING SIGNS UP TO 200LBS MUST BE ASSEMBLED, INSTALLED AND DISMANTLED BY LEVY. SIGN ASSEMBLY REQUIRES A 2 PERSON CREW. THE REQUIRED AMOUNT OF MAN HOURS TO ASSEMBLE YOUR SIGN(S) WILL BE ADDED TO YOUR ACCOUNT UPON COMPLETION OF THE WORK.

This order form is for labor and equipment that may be required for the hanging of signs, banners, decorations, etc. This order will be considered as a tentative reservation and **must be confirmed with a signed work order** at the Levy Exposition Services Inc. service desk.

A sign hanging crew consists of two men and a boom lift.

LABOR RATES

| | | |
|---------------------|------------------------------------------------------------------------------|------------------------------------------------------------------------------------------------------------------------------------------------------|
| REGULAR TIME | 8:00 AM - 4:30 PM Monday to Friday | Boom lift and two man crew - \$590.00 per Hour/ minimum 1 hour Additional Rigger(s) - \$150.00 per Person per Hour / minimum 1 hour |
| OVER TIME | 4:30 PM - 8:00 AM Monday to Friday, All day Saturday, Sunday and Holidays | Boom lift and two man crew - \$760.00 per Hour/ minimum 1 hour Additional Rigger(s) - \$215.00 per Person per Hour/ minimum 1 hour |

ESTIMATED INSTALLATION REQUIREMENTS

| REGULAR TIME | Laborers | Date Required | Start Time | Approx. Hours | Boom lift and two man crew - \$590.00 per Hour Additional Rigger(s) - \$150.00 per Person per Hour | \$ _____ Total |
|--------------|----------|---------------|------------|---------------|-------------------------------------------------------------------------------------------------------|----------------|
| | | | | | | |
| OVER TIME | Laborers | Date Required | Start Time | Approx. Hours | Boom lift and two man crew - \$760.00 per Hour Additional Rigger(s) - \$215.00 per Person per Hour | \$ _____ Total |
| | | | | | | |

ESTIMATED DISMANTLE REQUIREMENTS

| REGULAR TIME | Laborers | Date Required | Start Time | Approx. Hours | Boom lift and two man crew - \$590.00 per Hour Additional Rigger(s) - \$150.00 per Person per Hour | \$ _____ Total |
|--------------|----------|---------------|------------|---------------|-------------------------------------------------------------------------------------------------------|----------------|
| | | | | | | |
| OVER TIME | Laborers | Date Required | Start Time | Approx. Hours | Boom lift and two man crew - \$760.00 per Hour Additional Rigger(s) - \$215.00 per Person per Hour | \$ _____ Total |
| | | | | | | |

All Rates are based on current wage scales and are subject to change in accordance with existing wage scales at the time of the exposition.

NOTE: Any miscellaneous rigging supplies such as cable, shackles etc. required to install your sign will be calculated and added to your invoice upon completion of the installation

***PLEASE ADD 25% TO ORDERS PLACED AFTER FEBRUARY 1, 2023.**

SPECIAL INSTRUCTIONS

EXHIBITOR INFORMATION

COMPANY _____

CONTACT _____

BOOTH#

SUPERVISION SERVICES

(PLEASE INDICATE DESIRED SERVICE)

- EXHIBITOR SUPERVISED
- LEVY SUPERVISED (PLEASE ADD 50% FOR THIS SERVICE)

COST SUMMARY

| | | |
|---------------------------|-------------------|--|
| RATE ADJUSTMENT | (OFFICE USE ONLY) | |
| 25% CANCELLATION FEE | (OFFICE USE ONLY) | |
| SUBTOTAL | | |
| SUPERVISION 50% | | |
| ADDITIONAL 25% LATE ORDER | | |
| TOTAL | US DOLLARS | |

PLEASE REFER TO THE PAYMENT & CREDIT CARD CHARGE AUTHORIZATION FORM

ORDERS WILL NOT BE PROCESSED WITHOUT PAYMENT



PLEASE INCLUDE THIS FORM WITH YOUR HANGING SIGN ORDER FORM

STRUCTURAL INTEGRITY STATEMENT THIS FORM MUST BE RETURNED FOR ALL SUSPENDED STRUCTURES

_____, the contracted exhibitor at the DEMOLITION PHOENIX, FEBRUARY 22 - 25, 2023 and (if applicable), the display house or builder for the aforementioned exhibitor, do hereby certify and guarantee that the stress points for the hanging structure have been properly engineered and tested. We further certify that the structure can be hung safely and has been constructed to meet all applicable regulations and safety measures. We hereby release, indemnify and forever hold harmless the ASSOCIATION, PHOENIX CONVENTION CENTER, LEVY, and its subsidiaries, their directors, officers, employees, representatives, agents and contractors from and against any and all liability, claims, damage, loss, fines, or penalties arising from the installation, use or dismantling of this structure. All hang points supporting in excess of 200 lbs. may be verified (metered) on site at exhibitor's expense.

Exhibiting Company: _____ Booth #: _____

Authorized Signature: _____

Printed Name: _____ Date: _____

E-Mail: _____

Display House/Builder (if applicable): _____

Authorized Signature: _____

Printed Name: _____ Date: _____

E-Mail: _____

LEVY structural integrity statement



Fax: 253 437 0032
 14900 Interurban Avenue South, Suite 271
 Seattle, WA
 USA 98168
 Telephone: 253 437 0031
 E-mail: operations@levyexpo.com

DEMOLITION PHOENIX
 February 22 - 25, 2023
 Phoenix Convention Center
 Phoenix, AZ

LABOR ORDER FORM & INVOICE

SUPERVISION SERVICES (Please indicate desired service)

LEVY EXPOSITION SERVICES INC. SUPERVISED

MOVE IN MOVE OUT

LEVY EXPOSITION SERVICES INC. WILL SUPERVISE labor to unpack and install display before exhibitor arrival at show site and/or dismantle and pack display after show closing.

A **50% Surcharge** will be added to the labor rates below for this professional supervision.

EXHIBITOR SUPERVISED

MOVE IN MOVE OUT

EXHIBITOR WILL SUPERVISE the laborers provided by Levy Exposition Services Inc. for the installation and/or dismantle of the exhibit.

Supervisor's name _____

Starting time can be guaranteed only when labor is requested for the start of the working day at 8 AM. For all other starting times, check in at the **Exhibitor Service Desk** one-half (1/2) hour before time requested.

LABOR RATES

| | | |
|---------------------|--------------------------------------------------------------------------------------------|-------------------|
| REGULAR TIME | 8:00 AM - 4:30 PM Monday to Friday | \$150.00 per Hour |
| OVER TIME | Before 8:00 am and after 4:30 pm Monday to Friday, All day Saturday, Sunday, and holidays. | \$215.00 per Hour |

ESTIMATED INSTALLATION REQUIREMENTS

| | | | | | |
|---------------------|---------------|------------|-------------------|----------------|--------------------------------------------------------------------------------------------------------------------------------------------------------------------------|
| REGULAR TIME | ____ Laborers | ____ Hours | \$150.00 per Hour | \$ _____ Total | A minimum charge for labor is one (1) hour per laborer. Labor thereafter is charged in one-half (1/2) hour increments. Date Required _____ Start Time _____ |
| OVER TIME | ____ Laborers | ____ Hours | \$215.00 per Hour | \$ _____ Total | |

ESTIMATED DISMANTLE REQUIREMENTS

| | | | | | |
|---------------------|---------------|------------|-------------------|----------------|--------------------------------------------------------------------------------------------------------------------------------------------------------------------------|
| REGULAR TIME | ____ Laborers | ____ Hours | \$150.00 per Hour | \$ _____ Total | A minimum charge for labor is one (1) hour per laborer. Labor thereafter is charged in one-half (1/2) hour increments. Date Required _____ Start Time _____ |
| OVER TIME | ____ Laborers | ____ Hours | \$215.00 per Hour | \$ _____ Total | |

INBOUND FREIGHT INFORMATION ****BE SURE TO COMPLETE THE OUTBOUND FORM AS WELL****

| | | |
|--------------------------------------------------------------------------------|--------------|-----------------------|
| Carrier | Date Shipped | Pro Number |
| Number of Pieces | Weight | Arrival Date (Target) |
| <input type="checkbox"/> Loose Display <input type="checkbox"/> Crated Display | | |
| Quantity of Ladders Required (Optional) _____ | | |

EXHIBITOR INFORMATION

| | |
|---------------|---------------------|
| COMPANY _____ | |
| CONTACT _____ | BOOTH# _____ |

***PLEASE ADD 25% FOR ORDERS PLACED AFTER FEBRUARY 1, 2023.**

COST SUMMARY

| | | |
|---------------------------|-------------------|--|
| RATE ADJUSTMENT | (OFFICE USE ONLY) | |
| CANCELLATION FEE | (OFFICE USE ONLY) | |
| SUBTOTAL | | |
| SUPERVISION 50% | | |
| ADDITIONAL 25% LATE ORDER | | |
| TOTAL US DOLLARS | | |

PLEASE REFER TO THE PAYMENT & CREDIT CARD CHARGE AUTHORIZATION FORM

****ORDERS WILL NOT BE PROCESSED WITHOUT PAYMENT****

TERMS & CONDITIONS Gratuities in any form, including cash, gifts or labor hours for work not actually performed are prohibited. We reserve the right to adjust orders calculated incorrectly.

CANCELLATION FEE A one (1) hour "per person, per hour" charge will be applied for all canceled labor orders.

OUTBOUND SHIPPING - BOOTH I&D LABOR

| | | |
|----------------------------|------------------|----------------|
| Exhibitor Name: | Tel. #: | Booth # |
| Billing Address: | Fax #: | |
| City / State / Zip: | Auth. by: | |

1 Outbound Shipping Instructions

Please complete this section if Levy will be supervising booth labor.

*Exhibitor Outbound Shipping Instructions: At close of show, exhibitor freight will be shipped to the following address:
 If your freight is being forwarded to another show, be sure to include the name of show and your booth number.*

Company / Show: _____ **Booth #:** _____

Address: _____

City / State / Zip: _____

Attention: _____

Select Carrier

Ship via carrier of exhibitor's choice

Name of Carrier: _____

Ship via official show freight carrier

Select shipping method Ground Air **Select Service Provider:** _____

Please note:
 ■ If an exhibitor is using a carrier of his/her own choice (or not using the official show freight carrier,) the exhibitor is responsible for arranging for carrier to pick up at close of show.
 ■ Levy cannot guarantee pick up time for exhibitor appointed carriers. All shipments are moved out of the exhibit hall at Levy's discretion.

Please review the Quick Facts for the Carrier Check-in time

2 Billing Information

Please indicate billing information for carrier charges if different than above.

Bill Shipping Charges to (if different from above):

Shipper (signature): _____ **Shipper (print name):** _____

Freight Charges Billed To (Company/Show): _____

Address: _____

City / State / Zip: _____

Telephone: _____ **Attention:** _____

PAYMENT & LABOR

The terms and conditions set forth below become part of the contractual agreement between Levy Exposition Services Inc. and you, the EXHIBITOR. Acceptance of said terms and conditions will be construed when any of the following conditions are met:

- ~ **WHEN THE METHOD OF PAYMENT FORM IS SIGNED; OR**
- ~ **WHEN AN ORDER FOR LABOR, SERVICES, AND/OR RENTAL EQUIPMENT IS PLACED BY AN EXHIBITOR WITH LEVY EXPOSITION SERVICES INC.; OR**
- ~ **WHEN WORK IS PERFORMED ON BEHALF OF EXHIBITOR BY LABOR SECURED THROUGH LEVY EXPOSITION SERVICES INC.**

DEFINITIONS

"Levy Exposition Services Inc." ("LES"), and any sub-contractors affiliated within the show. The term EXHIBITOR shall be construed within the meaning of this contract as the EXHIBITOR and/or its employees, agents, representatives, and/or any Exhibitor Appointed Contractor (E.A.C.).

PAYMENT TERMS

Full payment, including any applicable tax, is due in advance or at show site. All payments must be in U.S. Funds and all checks must be drawn on a U.S. Bank. Orders received without advance payment or after the deadline date will incur additional [After Deadline] charges as indicated on each order form. All materials and equipment are on a rental basis for the duration of the show or event and remain the property of LES except where specifically identified as a sale. All LES rentals include delivery, installation and removal from EXHIBITOR's booth, unless stated otherwise. In case of cancellation, a one-hour "per person, per hour" charge will be applied to all labor, forklift and sign hanging orders that are not canceled in writing at least seven (7) days prior to the scheduled start time. If services have already been provided at the time of cancellation, 100% of original fee will be applied. It is EXHIBITOR'S responsibility to advise LES Exhibitor Services personnel of any problem with any order, and to check invoices for accuracy prior to the close of the exhibit. If EXHIBITOR is exempt from payment of sales tax, LES requires an exemption certificate for the State in which the services are to be used. Resale certificates are not valid unless EXHIBITOR is rebilling these charges to its customers. For International EXHIBITORS, LES requires 100% prepayment of advance orders, and any orders or services placed at show site must be paid at the show. For all others, should there be any pre-approved unpaid balance after the close of the show, terms will be net, due and payable in the UNITED STATES OF AMERICA, upon receipt of invoice. Effective 30 days after invoice date, any unpaid balance will bear a FINANCE CHARGE at the lesser of the maximum rate allowed by applicable law, or 1.5% per month, which is an ANNUAL PERCENTAGE RATE of 18%, and future orders will be on a pre-paid basis only. If any finance charge here under exceeds the maximum rate allowed by applicable law, the finance charge shall automatically be reduced to the maximum rate allowed, and any excess finance charge received by LES shall either be applied to reduce the principal unpaid balance or refunded to the payer. These payment terms and conditions shall be governed by and construed in accordance with the LAWS OF THE STATE OF ARIZONA. In the event of any dispute between EXHIBITOR and LES relative to any loss, damage, or claim, such EXHIBITOR shall not be entitled to and shall not withhold payment, or any partial payment, due to LES relative to any services, as an offset against the amount of any alleged loss or damage. Any claim against LES shall be considered a separate transaction, and shall be resolved on its own merits. LES reserves the right to charge EXHIBITOR for the difference between the EXHIBITOR's estimate of charges and the actual charges incurred by the EXHIBITOR, or for any charges that LES may be obligated to pay on behalf of the EXHIBITOR, including without limitation, any shipping charges.

LABOR PROVIDED UNDER THE SUPERVISION OF LES

RESPONSIBILITIES

LES shall be responsible for the performance of labor provided under this option. LES cannot assume responsibility for any acts of, or loss to, persons, parties and/or other contracting firms not under LES's direct supervision and control. In no event shall LES be liable for loss or damage caused by delay in labor beginning work when EXHIBITOR requests labor to begin later than the start of the working day. LES shall not be responsible for loss, delay or damage due to strike, lockouts, and/or work stoppages, or other causes beyond LES's reasonable control.

INDEMNIFICATION

LES agrees to indemnify, hold harmless, and defend EXHIBITOR from and against any and all demands, claims, causes of action, fines, penalties, damages, liabilities, judgments, and expenses (including but not limited to reasonable attorneys' fees and investigation costs) for bodily injury, including any injury to LES employees, or property damage arising out of work performed by labor provided by and supervised by LES, except when EXHIBITOR exercises direction and/or control over the work being performed.

LABOR PROVIDED UNDER THE SUPERVISION OF EXHIBITOR

RESPONSIBILITIES

EXHIBITOR shall be responsible for the performance of labor provided under this section. It is responsibility of EXHIBITOR to supervise labor secured through LES in a reasonable manner as to prevent bodily injury and/or property damage and also to direct them to work in a manner that is in compliance with LES Safe Work Rules and/or Federal, State, County and Local ordinances, rules and/or regulations, including but not limited to Show or Facility Management Rules and/or Regulations. It is the responsibility of EXHIBITOR to check in with the Service Desk to pick up labor, and to return to the Service Desk to release labor when the work is completed.

INDEMNIFICATION

EXHIBITOR agrees to indemnify, hold harmless, and defend LES from and against any and all demands, claims, causes of action, fines, penalties, damages, liabilities, judgements, and expenses (including but not limited to reasonable attorneys' fees and investigation costs) for bodily injury, including any injury to LES employees, and/or property damage arising out of work performed by labor provided by LES but supervised by EXHIBITOR. Further, EXHIBITOR's indemnification of LES includes any and all violations of Federal, State, County or Local ordinances, "Show Regulations and/or Rules" as published and/or set forth by Facility or Show Management, and/or directing labor provided by LES to work in a manner that violates any of the above rules, regulations, and/or ordinances.

IMPORTANT

PLEASE REFER TO LES's MATERIAL HANDLING TERMS AND CONDITIONS AS THEY RELATE TO MATERIAL HANDLING SERVICES. CONTRACTUAL TERMS DEPEND ON THE NATURE OF SERVICES SECURED BY EXHIBITOR THROUGH LES. TERMS & CONDITIONS MAY VARY FOR EACH TYPE OF SERVICE ORDERED THROUGH LES.

TERMS & CONDITIONS





Fax: 253 437 0032
14900 Interurban Avenue South, Suite 271
Seattle, WA
USA 98168
Telephone: 253 437 0031
E-mail: operations@levyexpo.com

DEMOLITION PHOENIX
February 22 - 25, 2023
Phoenix Convention Center
Phoenix, AZ

MOTORIZED VEHICLE ESCORT ORDER FORM

Submit this form if you wish to display a vehicle at show site. This form must be received by Levy Exposition Service prior to vehicles being received. Enter the total below to the Payment & Credit Card Charge Authorization Form. Orders received without full payment or credit card information will not be processed.

Advance Order Discount Deadline: February 1, 2023

FIRE REGULATIONS

Vehicle may only be displayed in accordance with local fire regulations and prior approval of Show Management

DELIVERY DETAILS

Date: _____ Time: _____

RATE

Vehicle: _____ x \$325.00 round trip = \$ _____ (subtotal)

Information

- Any vehicle brought into the exhibit hall will be escorted from the landing area to the booth.
- Escort fees are \$325.00 round trip.
- Display materials transported in display vehicles are subject to material handling charges.
- Weights will be estimated by Levy Exposition Service unless documentation is provided.
- 30% surcharge will apply to all vehicles brought in on overtime

TERMS / ORDER ESTIMATE

- Orders cancelled prior to move-in will be charged 50% of the original price.
- Orders cancelled after move-in begins will be charged 100% of the original price.
- Transfer this total to the Payment & Credit Card Charge Authorization Form.

Total Estimate: _____

Exhibiting Company: _____ Booth # _____



MATERIAL HANDLING FAQs

The following is a list of frequently asked questions pertaining to material handling and freight services. We strongly recommend that you read this document in its entirety to better familiarize yourself with the processes relating to material handling and freight services.

As the official service contractor, LEVY is the exclusive provider of freight services. Material handling includes unloading your exhibit material, storing up to 30 days in advance at the warehouse address, delivering to the booth, the handling of empty containers to and from storage, and removing of material from the booth for reloading onto outbound carriers. It should not be confused with the cost to transport your exhibit material to and from the convention or event. You have two options for shipping your advance freight — either to the warehouse or directly to show site.

HOW DO I SHIP TO THE ADVANCE WAREHOUSE?

- We will accept freight beginning 30 days prior to show move-in.
- To check on your freight arrival, call Exhibitor Services at the number listed on the Quick Facts.
- To ensure timely arrival of your materials at show site, freight should arrive by the deadline date listed on the Quick Facts and Shipping Instructions pages. Your freight will still be received after the deadline date, but additional charges will be incurred.
- The warehouse will receive shipments Monday through Friday, except holidays. Refer to the Shipping Instructions page for warehouse receiving hours.
- The warehouse will accept crates, cartons, skids, trunks/cases and carpets. Loose or pad-wrapped materials must be sent directly to show site.
- All shipments must have a bill of lading or delivery slip indicating the number of pieces, type of merchandise and weight.
- Certified weight tickets must accompany all shipments.
- Warehouse freight will be delivered to the booth prior to exhibitor setup.
- Please call the number located on the Quick Facts if you want to ship oversized material that requires special equipment to the warehouse.

HOW DO I SHIP TO SHOW SITE?

- Freight will be accepted only during exhibitor move-in. Please refer to the Quick Facts for the specific exhibitor move-in dates and times.
- All shipments must have a bill of lading or delivery slip indicating the number of pieces, type of merchandise and weight.
- Certified weight tickets must accompany all shipments.

WHAT ABOUT PREPAID OR COLLECT SHIPPING CHARGES?

- Collect shipments will be returned to the delivery carrier.
- To ensure that your freight does not arrive “collect,” mark your bill of lading “prepaid.”
- “Prepaid” designates that the transportation charges will be paid by the exhibitor or a third party.

HOW SHOULD I LABEL MY FREIGHT?

- The label should contain the exhibiting company name, the booth number and the name of the event.
- The specific shipping address for either the warehouse or show site can be found on the Quick Facts and Shipping Instructions pages.

HOW DO I ESTIMATE MY MATERIAL HANDLING CHARGES?

- Charges will be based on the weight of your shipment. Each shipment received is considered separately. The shipment weight will be rounded to the next 100 pounds. Each 100 pounds is considered one “cwt.” (one hundred weight). All shipments are subject to reweigh.
- On the Order Form, select whether the freight will arrive at the warehouse or be sent directly to show site.
- Next, select the category that best describes your shipment. There are three categories of freight:

Crated: material that is skidded or is in any type of shipping container that can be unloaded at the dock with no additional handling required.

Special Handling: material delivered by the carrier in such a manner that it requires additional handling, such as ground unloading, stacked and constricted space unloading, designated piece unloading, loads mixed with pad-wrapped material, loads failing to maintain shipping integrity, carpet and/or pad-only shipments, and shipments that require additional time, equipment or labor to unload. Federal Express, UPS and all van lines are included in this category due to their delivery procedures.

Uncrated: material that is shipped loose or pad-wrapped, and/or unskidded machinery without proper lifting bars or hooks.

- Add overtime charges for inbound if material is delivered to the booth during the overtime period stated on the Quick Facts and Shipping Instructions pages. This includes both warehouse and show site shipments.

- Add overtime charges for outbound if material is loaded onto the outbound carrier during the overtime period stated on the Quick Facts and Shipping Instructions pages.
- Add the late delivery charge listed on the Order Form if the shipment is accepted at the warehouse or at show site after the deadline date listed on the Quick Facts and Shipping Instructions pages.
- The above services, whether used completely or in part, are offered as a package and the charges will be based on the total inbound weight of the shipment.
- Shipments received without receipts or freight bills, such as UPS and Federal Express, will be delivered to the booth without guarantee of piece count or condition.

WHAT HAPPENS TO MY EMPTY CONTAINERS DURING THE SHOW?

- Pick up “Empty Labels” at the Service Center. Place a label on each container. Labeled containers will be picked up periodically and stored in non-accessible storage during the show.
- At the close of the show, the empty containers will be returned to the booth in random order. Depending on the size of the show, this process may take several hours.
- *Please note that LEVY will assume no liability for interrupted travel plans due to the length of time required for the empty container return. It is the responsibility of the exhibitor to schedule travel plans accordingly.*

HOW DO I PROTECT MY MATERIALS AFTER THEY ARE DELIVERED TO THE SHOW OR BEFORE THEY ARE PICKED UP AFTER THE SHOW?

- Consistent with trade show industry practices, there may be a lapse of time between the delivery of your shipment(s) to your booth and your arrival. The same is true for the outbound phase of the show — the time between your departure and the actual pick-up of your materials. During these times, your materials will be left unattended. We recommend that you arrange for a representative to stay with your materials or that you hire security services to safeguard your materials.

HOW DO I SHIP MY MATERIALS AFTER THE CLOSE OF THE SHOW?

- Each shipment must have a completed Material Handling Agreement in order to ship materials from the show. All pieces must be labeled individually.
- To save time, complete and submit the Outbound Shipping Form in advance, or you may contact the Service Center at show site for your shipping documents. The Material Handling Agreement and labels will be processed and available prior to show closing.
- After materials are packed, labeled, and ready to be shipped, the completed Material Handling Agreement must be turned in at the Service Center.
- Call your designated carrier with pick-up information. Please refer to the Quick Facts and Shipping Instructions pages for specific dates and times. In the event your selected carrier fails to show on final move-out day, your shipment will either be rerouted to LEVY’s carrier choice or delivered back to the warehouse at exhibitor’s expense.
- For your convenience, show-recommended carriers will be on site to handle outbound transportation.

WHERE DO I GET A FORKLIFT?

- Forklift orders to install or dismantle your booth after materials are delivered may be ordered in advance or at show site. We recommend that you order in advance to avoid additional charges at show site. Refer to the Order Form for available equipment.
- Advance and show-site orders for equipment and labor will be dispatched once a company representative signs the labor order at the Service Center.
- Start time is guaranteed only when equipment is requested for the start of the working day.

DO I NEED INSURANCE?

- Be sure your materials are insured from the time they leave your firm until they are returned after the show. It is suggested that exhibitors arrange all-risk coverage. This can be done by riders to your existing policies.
- All materials handled by LEVY are subject to the enclosed Terms and Conditions.

OTHER AVAILABLE SERVICES (may not be available in all locations)

- Cranes
- Scissor lifts, condors
- Access storage at show site
- Exhibit transportation services (see enclosed Liberty Convention Freight form)
- Security storage at show site
- Short-term and long-term warehouse storage
- Local pick-up and delivery



Fax: 253 437 0032
 14900 Interurban Avenue South, Suite 271
 Seattle, WA
 USA 98168
 Telephone: 253 437 0031
 E-mail: operations@levyexpo.com

DEMOLITION PHOENIX
 February 22 - 25, 2023
 Phoenix Convention Center
 Phoenix, AZ

MATERIAL HANDLING ORDER FORM & INVOICE

MATERIAL HANDLING SERVICES

Crated: material that is skidded or is in any type of shipping container that can be loaded at the dock with no additional handling required.

Special Handling: material delivered by the carrier in such a manner that it requires additional handling, such as ground unloading, side door unloading, constricted space loading, designated piece loading, and stacked shipments. Federal Express and UPS and All Van Lines are included in this category due to their delivery procedures.

Uncrated: material that is shipped loose or pad-wrapped, and/ or unskidded machinery without proper lifting bars or hooks.

Small Package Shipment: A small package shipment is a shipment totaling any number of pieces with a combined weight not to exceed 30lbs. that is received on the same day, from the same shipper and delivered by the same carrier.

Dedicated Delivery from Advance Warehouse: Any shipment(s) received at the Advance Warehouse after **Monday, February 20, 2023.**

Off Target: Shipment(s) received at the **Phoenix Convention Center** prior to **8:00 am on February 22, 2023.**

Marshalling Yard Usage Fee: A \$30.00 usage fee will apply to all carriers. This fee will be applied to inbound and outbound carriers.

Normal Warehouse Hours for Receiving Freight: 9:00 A.M. To 3:00 P.M. Monday through Friday, Holidays excluded.

Straight Time - 8:00 A.M. To 4:30 P.M. Monday through Friday

Overtime - 4:30 P.M. To 8:00 A.M. Monday through Friday, all day Saturday, Sunday, and Holidays.

**** Please be advised that overtime charges may apply during move-in or move-out.****

| DESCRIPTION | CWT Price | Minimum |
|---------------------------------------------------------------------------------------|-----------------|-----------|
| Advance Shipment | | |
| Crated or Skidded Shipment..... | \$ 170.00 | \$ 340.00 |
| Special Handling Shipment..... | 215.00 | 430.00 |
| Late to Warehouse (in addition to base rate)..... | 42.00 | 84.00 |
| Small Package shipment (shipments less than 30 lbs)..... | 55.00 | 55.00 |
| Dedicated Delivery from Advance Warehouse (in addition to late to warehouse fees).... | 650.00 flat fee | |
| Showsite Shipment | | |
| Crated or Skidded Shipment..... | \$ 155.00 | \$ 310.00 |
| Special Handling Shipment..... | 195.00 | 390.00 |
| Uncrated or Pad Wrapped Shipment..... | 210.00 | 420.00 |
| Small Package shipment (shipments less than 30 lbs)..... | 55.00 | 55.00 |
| Overtime Charge (Inbound)(In addition to above rates) | | |
| Applies to all above shipments..... | \$ 45.00 | \$ 90.00 |
| Overtime Charge (Outbound)(In addition to above rates) | | |
| Applies to all above shipments..... | \$ 45.00 | \$ 90.00 |

PLEASE NOTE: Total weight is in lbs. With a minimum shipment of 200 lbs. Please round up to the next 100 lbs when filling out the weight of your shipment.

| Description | Weight | CWT | Unit Price | Estimated Total Charges |
|-------------------------------------------------------------------------------------------------------------------------------------------------------------------------------------------------------------------------------------------------------------------------------------------------------------------------------|----------|------------|----------------------|-------------------------|
| Crated or Skidded Shipment | 1200 LBS | ÷ 100 = 12 | \$170.00 | \$2,040.00 |
| E X A M P L E | | | | |
| PLEASE NOTE: Acceptance of Terms & Conditions will be construed when the Material Handling Service Agreement is signed; or when exhibitor's materials are delivered to Levy Exposition Services Inc. warehouse or to a SHOW / EXPOSITION SITE for which Levy Exposition Services Inc. is the official show contractor. | | | | |
| RATE ADJUSTMENT | | | (OFFICE USE ONLY) | |
| SUBTOTAL | | | | |
| TOTAL | | | U. S. DOLLARS | |

EXHIBITOR INFORMATION

COMPANY

CONTACT

BOOTH#

PLEASE REFER TO THE PAYMENT & CREDIT CARD CHARGE AUTHORIZATION FORM

ORDERS WILL NOT BE PROCESSED WITHOUT PAYMENT



Fax: 253 437 0032
 14900 Interurban Avenue South, Suite 271
 Seattle, WA
 USA 98168
 Telephone: 253 437 0031
 E-mail: operations@levyexpo.com

DEMOLITION PHOENIX
February 22 - 25, 2023
Phoenix Convention Center
Phoenix, AZ

MATERIAL HANDLING FOR MACHINERY ORDER FORM & INVOICE

Submit this form to order material handling services for machinery and attachments. Levy will unload equipment and place in your booth. Use the rates and calculator below to estimate your material handling charges for machinery and attachments.

MACHINERY MATERIAL HANDLING RATE SCHEDULE

Machinery and attachments arriving at the park will be spotted within a 6" tolerance one time after removal from the truck, provided that the following conditions are adhered to:

- The exhibitor, or exhibitor's representative, supervises spotting
- The area within the booth is clearly marked to indicate the machine's position
- No rigging, bolting, unskidding, or attaching to other equipment is conducted

All machinery and attachments should be consigned directly to show site. Machinery and attachments received at the advance warehouse will be transferred to show site at the rate of \$175.00 per 100 pounds with a 1,000 pound minimum.

All shipments must be accompanied by a certified weight ticket. Shipments will not be unloaded without this ticket.

Mobile rates will apply to rolling stock, licensed vehicles, self-propelled or towed, or shipments received at show site, which must be driven by the exhibitor, or towed to the booth area, under Levy supervision. The same procedures will be used during the move-out.

Planking, if required, will be charged on a time and material basis.

For any questions about Arizona's rules and regulations please visit:
<https://azdot.gov/motor-vehicles/enforcement/commercial-vehicle-permits/rules-and-regulations>

MACHINERY MATERIAL HANDLING RATES (per cwt)

| Inbound Site Shipments | One Way Rate |
|---------------------------------------------------|--------------|
| 1 - 5,000 pounds | \$29.50 |
| 5,001 - 8,000 pounds | \$27.50 |
| 8,001 - 16,000 pounds | \$25.50 |
| 16,001 - 20,000 pounds | \$24.00 |
| 20,001 pounds and greater | \$23.00 |
| Machinery handled on overtime - add an additional | 35% |

CALCULATE ESTIMATED MATERIAL HANDLING FOR MACHINERY

| Date of Arrival | Estimated Weight | CWT | Rate per CWT | Estimated Cost |
|-----------------|------------------|-----|--------------|----------------|
| | | | | |
| | | | | |

Please contact Steve Moody with Levy Exposition Services to confirm time and date of delivery.
Telephone: 602 751 7124 **Email: smoody@levyexpo.com**

EXHIBITOR INFORMATION

COMPANY _____

| | |
|-------------------|--------------|
| CONTACT _____ | BOOTH# _____ |
| CELL NUMBER _____ | EMAIL _____ |

COST SUMMARY

| | | |
|-------------------------|-------------------|--|
| RATE ADJUSTMENT | (OFFICE USE ONLY) | |
| CANCELLATION FEE | (OFFICE USE ONLY) | |
| SUBTOTAL | | |
| TOTAL US DOLLARS | | |

PLEASE REFER TO THE PAYMENT & CREDIT CARD CHARGE AUTHORIZATION FORM
****ORDERS WILL NOT BE PROCESSED WITHOUT PAYMENT****

TERMS & CONDITIONS Gratuities in any form, including cash, gifts or labor hours for work not actually performed are prohibited. We reserve the right to adjust orders calculated incorrectly.

CANCELLATION FEE A one (1) hour "per person, per hour" charge will be applied for all canceled labor orders.

To ensure a smooth targeted move-in, submit this form and the previous form, Material Handling for Machinery, to order labor and equipment to unload trucks and place machinery in your booth.

Number of pieces of machinery over 5,000 lbs: _____

Weight of heaviest piece of machinery: _____

How many over 10,000 lbs: _____

Weights of each: _____

Total weight of all machinery: _____

What is your machinery handled by:

Forklift Crane

Will machinery need assembly:

Yes No

Assemble at booth:

Yes No

Equipment needed for assembly:

Forklift Crane Size: _____

Estimated assembly time: _____

Showsite Contact: _____

Showsite Contact Phone Number: _____

SHIPPING INSTRUCTIONS

SHIPMENTS CAN BE SENT DIRECTLY TO THE SHOW-SITE ON MOVE-IN DAY, OR TO THE ADVANCE WAREHOUSE UP TO THIRTY DAYS PRIOR TO MOVE-IN.

All freight shipped to the advance receiving warehouse must be properly crated, boxed, or stretch wrapped on pallets.

ADVANCE RECEIVING

For advance receiving, mail or fax the Material Handling Order Form & Invoice with pre-payment to LEVY EXPOSITION SERVICES INC. Shipments sent collect **WILL NOT** be accepted.

Advance receiving includes the following:

- receiving your material at the warehouse up to thirty days in advance of the move-in day
- delivering the shipment to your booth at the facility
- removing empty crates from your booth to a designated storage area
- returning your empty crates to your booth at the close of the show
- loading your crates onto your designated carrier at the close of the show

The material handling services provided by LEVY EXPOSITION SERVICES INC. end with the close of the show. It is the responsibility of the exhibitor to make appropriate arrangements with a carrier for shipping following the close of the show. Please make special note of the allotted move-out times and days, and confirm with your carrier that they are able to meet these allotted times.

Please remove all old shipping labels and ensure that all freight destined for the advance warehouse is labeled with the following information:

DEMOLITION PHOENIX
COMPANY NAME & BOOTH #
Levy Exposition Services Inc.
c/o Liberty CFS NV, Inc.
2021 S 51st Street
Phoenix, AZ 85043

Shipments may be sent to the advance warehouse up to thirty days prior to the move-in day for the show. All shipments however, must be received at the warehouse a minimum of one week (seven days) in advance of the show move-in date. Shipments received less than seven days prior to the move-in day are subject to extra charges and delivery time **will not** be guaranteed. All shipments must be received at the advance warehouse between the hours of 08:00 and 15:00, Monday to Friday, no earlier than **January 18, 2023** and no later than **February 15, 2023**. Shipments that arrive prior to **January 18, 2023** or after **February 15, 2023** will incur a surcharge of \$42.00 per hundred weight surcharge with at \$84.00 minimum.

ANY SHIPMENT(S) RECEIVED AT THE ADVANCE WAREHOUSE AFTER MONDAY, FEBRUARY 20, 2023 WILL INCUR A CHARGE OF \$650.00 IN ADDITION TO LATE TO WAREHOUSE FEES.

Shipments must include an official weight ticket or bill of lading.

SHIPPING INSTRUCTIONS (CONT'D.)

SHOW-SITE RECEIVING

For show-site receiving, mail or fax the Material Handling Order Form & Invoice with pre-payment to LEVY EXPOSITION SERVICES INC. Shipments sent collect **WILL NOT** be accepted.

Show-site receiving includes the following:

- receiving and signing for your shipment on your behalf
- delivering the shipment to your booth at the facility
- removing empty crates from your booth to a designated storage area
- returning your empty crates to your booth at the close of the show
- loading your crates onto your designated carrier at the close of the show

The material handling services provided by LEVY EXPOSITION SERVICES INC. end with the close of the show. It is the responsibility of the exhibitor to make appropriate arrangements with a carrier for shipping following the close of the show. Please make special note of the allotted move-out times and days, and confirm with your carrier that they are able to meet these allotted times.

Please remove all old shipping labels and ensure that all freight destined for show-site receiving is labeled with the following information:

**DEMOLITION PHOENIX
COMPANY NAME & BOOTH #
Phoenix Convention Center
c/o Levy Exposition Services Inc.
100 N 3rd Street
Phoenix, AZ 85043**

PLEASE NOTE THAT SHIPMENTS CANNOT BE RECEIVED AT THE PHOENIX CONVENTION CENTER PRIOR TO 8:00 AM ON WEDNESDAY, FEBRUARY 22, 2023.

ALL SHIPMENTS MUST INCLUDE A CERTIFIED WEIGHT TICKET OR BILL OF LADING. IN THE EVENT THAT YOUR SHIPMENT(S) DOES NOT INCLUDE A CERTIFIED WEIGHT TICKET, IT WILL BE WEIGHED ON-SITE AND A SURCHARGE WILL BE APPLIED.

LIMITS OF LIABILITY

See Material Handling Terms & Conditions Sheet enclosed.

EAST GARAGE - TONTO MARSHALLING YARD & DOCK ACCESS GUIDE

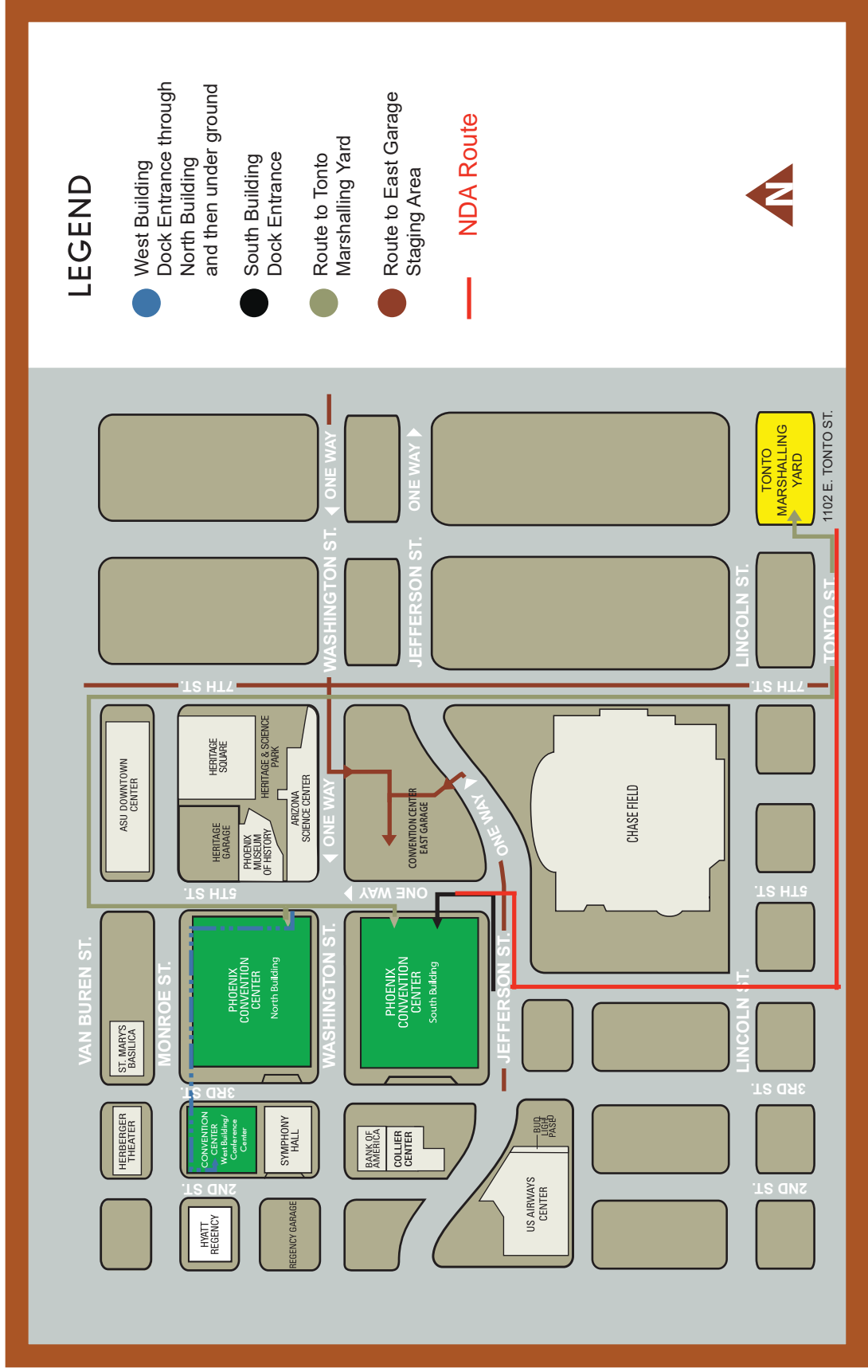

MATERIAL HANDLING

Acceptance of said terms and conditions will be constructed when any of the following conditions are met:

- ~ **THE MATERIAL HANDLING ORDER FORM AND INVOICE IS SIGNED; OR**
- ~ **WHEN EXHIBITOR'S MATERIALS ARE DELIVERED TO LES'S WAREHOUSE OR TO A SHOW/ EXPOSITION SITE FOR WHICH LEVY EXPOSITION SERVICES INC. IS THE OFFICIAL SHOW CONTRACTOR; OR**
- ~ **WHEN AN ORDER FOR LABOR AND/ OR RENTAL EQUIPMENT IS PLACED BY AN EXHIBITOR WITH LEVY EXPOSITION SERVICES INC.**

TERMS & CONDITIONS

1. **DEFINITIONS.** "Levy Exposition Services Inc" ("LES"), and any sub-contractors affiliated within the show.
2. **PACKAGING AND CRATES.** LES shall not be responsible for damage to loose, uncrated materials, pad-wrapped or shrink-wrapped materials, glass breakage, concealed damage, carpets in bags or poly, or materials improperly packed. In addition, LES shall not be responsible for crates and packaging which are unsuitable for handling, in poor condition, or have prior damage. Crated and packaging should be of a design to adequately protect contents for handling by forklift and similar means.
3. **EMPTY CONTAINERS.** Empty container labels will be available at the show site service desk. Affixing labels to the containers is the sole responsibility of EXHIBITOR or his representative. All previous labels must be removed or obliterated. LES assumes no responsibility for: Error in the above procedures; Removal of containers with old empty labels & without LES labels; or Improper information on empty labels. LES WILL NOT BE LIABLE FOR LOSS OR DAMAGE TO CRATES AND CONTAINERS OR THEIR CONTENTS WHEN SAID ITEMS ARE IN EMPTY CONTAINER STORAGE.
4. **INBOUND SHIPMENT(S).** Consistent with trade show industry practices, there may be a lapse of time between the delivery of shipment(s) to the booth and the arrival of EXHIBITOR or his representative, and during such time the materials will be left unattended. LES WILL NOT BE RESPONSIBLE OR LIABLE FOR ANY LOSS, DAMAGE, THEFT, OR DISAPPEARANCE OF EXHIBITOR'S MATERIALS AFTER SAME HAVE BEEN DELIVERED TO EXHIBITOR'S BOOTH AT SHOW SITE. LES highly recommends the securing of security services for Facility or Show Management.
5. **OUTBOUND SHIPMENT(S).** Consistent with trade show industry practices, there may be a lapse of time between the completions of packing and the actual pickup of materials from the booths for loading onto a carrier and during such time the materials will be left unattended. LES WILL NOT BE RESPONSIBLE OR LIABLE FOR ANY LOSS, DAMAGE, THEFT, OR DISAPPEARANCE OF EXHIBITOR'S MATERIALS BEFORE SAME HAVE BEEN PICKED UP FOR RELOADING AT THE CONCLUSION OF THE EVENT. LES highly recommends the securing of security services from Facility or Show Management. All Material Handling Agreements submitted to LES by EXHIBITOR will be checked at the time of pickup from booth and corrections will be made where discrepancies exist between the quantities of times listed by EXHIBITOR and the actual count of such items in the booth at the time of pickup.
6. **LES'S RESPONSIBILITIES.** LES shall be responsible only for those services which it directly provides. LES assumes no responsibility for any persons, parties, or other contracting firms not under LES's direct supervision and control. LES shall not be responsible for loss, delay, or damage due to strike, lockouts, work stoppages, natural elements, vandalism, acts of God, civil disturbances, power failure, explosion, acts of terrorism or war, other causes beyond LES's reasonable control, nor for ordinary wear & tear in the handling of materials.
7. **INSURANCE.** It is understood that LES is not an insurer. Insurance on exhibit materials, if any, shall be obtained by EXHIBITOR in amounts and for perils determined by EXHIBITOR. EXHIBITOR agrees to provide LES with a release of subrogation to the extent of any insurance settlement received.
8. **CLAIM(S) FOR LOSS.** Claims for loss or damage must be reported at show-site.
 - A. **PAYMENT FOR SERVICES MAY NOT BE WITHHELD.** In the event of any dispute between the EXHIBITOR shall not be entitled to and shall not withhold payment, or any partial payment due to LES for its services, as an offset against the amount of any alleged loss or damage.
 - B. **MAXIMUM RECOVERY.** If found damaged LES's sole and exclusive MAXIMUM liability for loss or damage to EXHIBITOR's materials and EXHIBITOR's sole and exclusive remedy is limited to \$.50 per pound article with a maximum liability of \$100.00 per item, or \$1,500.00 per shipment.
9. **JURISDICTION.** THIS CONTRACT SHALL BE CONSTRUED UNDER THE LAWS OF THE STATE OF ARIZONA WITHOUT GIVING EFFECT TO ITS CONFLICT OF LAWS RULES. EXCLUSIVE VENUE FOR ALL DISPUTES ARISING OUT OF OUR RELATING TO THIS CONTRACT SHALL RESIDE IN A COURT OF COMPETENT JURISDICTION IN PHOENIX, ARIZONA.
10. **INDEMNIFICATION.** EXHIBITOR agrees to indemnify, forever hold harmless and defend LES, its employees, directors, officers, and agents from and against any and all demands, claims, causes of action, fines, penalties, damages (including consequential), liability, judgments, and expenses (including but not limited to reasonable attorney's fees and investigation costs) on account of personal injury, death, or damage to or loss of property or profits arising out of, or contributed to, by any of the following:
 - EXHIBITOR's negligent supervision of any labor secured through LES, or the negligent supervision of such labor by any of EXHIBITOR's employees, agents, representative, customers, invitees and/or Exhibitor Appointed Contractor (EAC).
 - EXHIBITOR's negligence, willful misconduct, or deliberate act of EXHIBITOR's employees, agents, representatives, customers, invitees and/or any Exhibitor Appointed Contractor (EAC) at the show or exposition to which this contract relates.
 - EXHIBITOR's violation of U.S.A. or Local ordinances or the violation of Show Regulations and/or Rules as published and set forth by Facility and/or Show Management.
 - EXHIBITOR's inclusion of illegal substances, hazardous materials or waste in any shipment placed with LES and for the violation of the representations and warranties made regarding hazardous materials made on the front of this Agreement.
11. **MISCELLANEOUS.** EXHIBITOR, as a material part of the consideration LES for material handling and transportation services, waives and releases all claims against LES, its employees, agents, officers, and directors, with respect to all matters for which LES has disclaimed liability pursuant to the provisions of this contract. The EXHIBITOR acknowledges that he or she has read this agreement, understands it and agrees to be bound by its terms, and further agrees that it is the complete and exclusive agreement between the parties. The invalidity or enforceability of any provision hereof shall not affect, modify, or impair the validity and enforceability of all provisions herein.





ADVANCE WAREHOUSE

TO: _____
(EXHIBITOR NAME)

BOOTH # _____

**Levy Exposition Services Inc.
c/o LIBERTY CFS NV, INC.
2021 S 51st Street
Phoenix, AZ 85043**

EVENT NAME:

**DEMOLITION
PHOENIX**

NO. _____ # of _____ PCS.



ADVANCE WAREHOUSE

TO: _____
(EXHIBITOR NAME)

BOOTH # _____

**Levy Exposition Services Inc.
c/o LIBERTY CFS NV, INC.
2021 S 51st Street
Phoenix, AZ 85043**

EVENT NAME:

**DEMOLITION
PHOENIX**

NO. _____ # of _____ PCS.

The above labels are provided for your convenience.
Place one on each piece shipped to the ADVANCE WAREHOUSE.
If more labels are needed, copies are acceptable.



SHOW SITE

TO: _____
(EXHIBITOR NAME)

BOOTH # _____

Phoenix Convention Center
c/o Levy Exposition Services Inc.
100 N 3rd Street
Phoenix, AZ 85004

EVENT NAME:

**DEMOLITION
PHOENIX**

NO. _____ # of _____ PCS.



SHOW SITE

TO: _____
(EXHIBITOR NAME)

BOOTH # _____

Phoenix Convention Center
c/o Levy Exposition Services Inc.
100 N 3rd Street
Phoenix, AZ 85004

EVENT NAME:

**DEMOLITION
PHOENIX**

NO. _____ # of _____ PCS.

The above labels are provided for your convenience.
Place one on each piece shipped to the SHOW SITE.
If more labels are needed, copies are acceptable.



Catch The LibertyCFS Caravan From DEMO PHX to CONEXPO

- Book your space on the Caravan before you arrive at Demolition Phoenix 2023
- Your shipment moves direct to CONEXPO without stopping
- Preferred DEMO/CONEXPO Caravan pricing
- Pre-printed Caravan material handling forms
- Labels
- Stop by the LibertyCFS Service Desk and speak to our Rep

**DON'T DELAY
BOOK TODAY!**

Contact LibertyCFS at
866.938.1092 ext. 101
exhibitorservices@libertycfs.us





"Delivering Freedom®"



MOVE YOUR EXHIBIT WITH PEACE OF MIND

**THE FREIGHT & CUSTOMS PARTNER YOU CAN RELY ON
FULLY DEDICATED TO YOUR CONVENTION AND TRADE SHOW SUCCESS**

Putting service first and leveraging our 42 years of freight & customs experience



Transportation Services

- Ground Freight (LTL)
- Full Load
- International Freight Forwarding
- Customs Brokerage Services
- Exclusive Use Full Trailer



Customized Solutions

- Door to door service
- Catering to your specific needs
- Single point of contact
- 24/7 customer attention
- Committed to excellence

Dedicated to delivering safely and on time every time.

100% satisfaction guaranteed or your money back. That's the Liberty CFS promise.



**Call Toll Free 1-866-938-1092 or 1.905.338.3993 Fax: 1.905.338.1092
email: exhibitorservices@libertycfs.us - www.libertycfs.us**

LAS VEGAS | TORONTO





LibertyCFS NV, Inc.

A Veteran Owned Company
Delivering Freedom

exhibitorservices@libertycfs.us

www.libertycfs.us

Tel. (905) 338-3993 Fax: (905) 338-1092

FREIGHT & CUSTOMS ORDER FORM

1 Please accept this form as authority for LibertyCFS NV, Inc. to provide the services listed below. A second form is required for additional events.

Adobe Acrobat Reader DC may be required for completion of form. Click image to download 

Freight & Customs
 Freight Only
 Customs Only
 Return Only

2a PICK-UP LOCATION

Company Name _____
 Address1 _____
 Address2 _____
 City _____ State _____ ZipCode _____
 Contact _____ Phone # _____
 Email _____ IRS/Tax ID# _____

3 DELIVERY TO ADDRESS

Exhibiting Company Name _____ Booth # _____
 Show Name _____
 Address1 _____
 Address2 _____
 City _____ State _____ ZipCode _____
 Onsite Contact _____ Cell Phone # _____

2b SERVICES

P/U Date _____ Hours _____ From _____ To _____
 Dlv Date _____ Hours _____

Express
 Economy LTL 7 - 10 Days
 Int'l
 Inside
 Liftgate
 Dock
 Other _____

4 RETURN TO

Check Box if the Return address is the same as 2a

Shipper _____
 Address1 _____
 Address2 _____
 City _____ State _____ ZipCode _____
 Contact _____ Phone # _____
 PU Date _____ Arrive by _____

5 PACKAGE INFO

Carton(s)/Box
 Vinyl Case(s)/Color
 Wooden Crate(s)
 Trunk(s) / On Wheels
 Skid(s) - to contain # _____ of pieces

| PCS | DIMENSIONS (L x H x W) | WGT |
|---------------------|------------------------|---------------------|
| | | |
| | | |
| | | |
| | | |
| | | |
| | | |
| | | |
| | | |
| TOTAL PIECES | | TOTAL WEIGHT |



6 VALUE

Declared Value for Carriage: The declared value for carriage of this shipment is agreed to and understood to be \$0.50 per pound multiplied by the number of pounds of that part of the shipment lost or damaged but not less than \$50.00 per shipment unless a value is declared below and applicable charges paid thereon. The liability of Carrier for loss/damage are subject to the terms and conditions. LibertyCFS NV, Inc charges 4% per \$1000, Min \$40.

Exclusion: Does not include TV(s)/Monitor(s) _____

DECLARED VALUE _____

7 PAYMENT

Credit Card Information / Billing Address   

Credit Card Number _____ Security Code _____ Exp. Date ____ / ____
 I hereby authorize the use of this card for payment of services related to this Order Form. I understand that declined credit cards are subject to a 30% surcharge.

Address _____ Signature _____
 City _____ State _____ ZipCode _____
 Phone _____ Email _____

Comments: Include any additional comments that will be helpful for the movement of freight and contents

Print



Fax: 253 437 0032
 14900 Interurban Avenue South, Suite 271
 Seattle, WA
 USA 98168
 Telephone: 253 437 0031
 E-mail: operations@levyexpo.com

DEMOLITION PHOENIX
February 22 - 25, 2023
 Phoenix Convention Center
 Phoenix, AZ

REQUEST FOR SET-UP BY NON-OFFICIAL CONTRACTOR

The unpacking, erection, assembling, dismantling, and packing of displays and equipment must be done by the correct type of labor. Levy Exposition Services Inc., the official contractor, will have skilled craftsmen available to assist Exhibitors. Arrangements for labor should be made through Levy Exposition Services in advance whenever possible. Official labor forms are included in the Exhibitor Service Manual.

Exceptions to the foregoing will be considered only in cases where permission has been requested in writing by the Exhibitor and **received by Levy Exposition Services Inc. no later than February 1, 2023.** Exceptions will be granted only if it will not interfere with or prejudice the orderly set-up, interim service, or dismantling of the Exposition. An exception will not be granted if it is inconsistent with the commitments made and obligations assumed by Management in any contract with service contractors or its lease with the **Phoenix Convention Center.** For services such as electrical, plumbing, telephone, drayage, rigging and booth cleaning, no exception will be made, and the contractor designated by Management will be used.

All agents representing the Exhibitor must be fully identified by the official Management badge. All agents or representatives who are performing services other than the Exhibitor's own employees must provide Levy Exposition Services with **Certificates of Insurance naming Levy Exposition Services Inc., National Demolition Association, Demolition Phoenix, and the Phoenix Convention Center as additional insured's by February 1, 2023.** These Certificates of Insurance must include public liability and property damage insurance for at least \$1,000,000, and workmen's compensation insurance in accordance with local law.

Exhibitors wishing to use a contractor other than Levy Exposition Services Inc. to set up and dismantle their exhibits must fill out this form and return to us no later than February 1, 2023. If this form and the certificate of insurance from the non-official contractor is not received by February 1, 2023, your non-official contractor will be allowed to supervise only. All labor must then be hired from Levy Exposition Services Inc. for installation and dismantle of the exhibit.

**ORIGINAL CERTIFICATES ONLY
 PHOTOSTATS OR FACSIMILES WILL NOT BE ACCEPTED**

Name of Exhibiting Company: _____ Booth Number: _____

Contracting Company Name: _____

Contracting Company Address: _____

City: _____ State: _____ Zip: _____ Telephone: _____ Fax: _____

Estimated Arrival at Show _____ Number of Workers: _____

Authorized By: _____ Title: _____
 (Sign & Print Name)

ACCESSIBLE STORAGE INFORMATION

Accessible storage will be available to you at this show. You must sign up for the service at the Levy Exposition Services Inc. desk and pick up your accessible storage labels. All freight received at the show will be delivered to your booth space first, and when properly labeled will be placed in accessible storage.

This is not an order form. This service must be ordered on site.

Accessible Storage is **NOT** Secured Storage.

NOTE: Accessible Storage items are not necessarily the first items returned to your booth at the close of the show.

Rates are for SET UP, STORAGE SPACE PER DAY, AND EACH TIME ACCESSED, and are as follows:

SET UP:

One time set up charge of \$160.00

STORAGE RATES:

(RATES ARE PER SQUARE FOOT INCREMENTS OR PORTION THEREOF PER DAY.)

| | | |
|-----------|-------------|----------|
| 0 - 25 | square feet | \$150.00 |
| 26 - 50 | square feet | \$200.00 |
| 51 - 100 | square feet | \$250.00 |
| 101 - 150 | square feet | \$300.00 |
| 151 - 200 | square feet | \$350.00 |

ACCESS RATES:

There is a 1/2 hour labor charge (minimum) each time items are placed into or removed from accessible storage. This charge will be applied at the corresponding rate for the time it is accessed.

LABOR RATES:

| | | |
|----------------------|--------------------------------------------------------------------|-------------------|
| STRAIGHT TIME | 8:00 AM - 4:30 PM Monday to Friday | \$150.00 per Hour |
| OVER TIME | 4:30 PM - 8:00 AM Monday to Friday, All day Saturday and Sunday | \$215.00 per Hour |



TRADE SHOW

2023 FURNITURE PRICE LIST

FABRIC COLLECTIONS

AURORA



Aurora Sofa
90"W x 33"D x 30"H
Trade Show Price: \$941.00



Aurora Chair
39"W x 33"D x 30"H
Trade Show Price: \$560.00

CHATEAU



Chateau Sofa
82"W x 35"D x 36"H
Trade Show Price: \$941.00



Dijon Chair
24"W x 29"D x 35"H
Trade Show Price: \$407.00



Elan Chair
30"W x 29"D x 37"H
Trade Show Price: \$407.00



Marteen Chair
23"Square x 40"H
Trade Show Price: \$407.00

CROMWELL



Cromwell Sofa
78"W x 32"D x 29"H
Trade Show Price: \$941.00



Cromwell Chair
32"W x 32"D x 29"H
Trade Show Price: \$560.00

JADE



Jade Sofa
82"W x 36"D x 34"H
Trade Show Price: \$777.00



Jade Chair
32"W x 36"D x 34"H
Trade Show Price: \$453.00



Jade Bench Ottoman
48"W x 24"D x 19"H
Trade Show Price: \$345.00

FABRIC COLLECTIONS

MADISON



Madison Sofa
86"W x 34"D x 34"H
Trade Show Price: \$777.00



Madison Chair
33"W x 34"D x 34"H
Trade Show Price: \$453.00



Madison Bench - Sky
48"W x 24"D x 17"H
Trade Show Price: \$319.00



Madison Ottoman - Apricot
24"Square x 17"H
Trade Show Price: \$204.00



Madison Ottoman - Sand Dollar
24"Square x 17"H
Trade Show Price: \$204.00



Madison Ottoman - Sunflower
24"Square x 17"H
Trade Show Price: \$204.00



Madison Ottoman - Willow
24"Square x 17"H
Trade Show Price: \$204.00

MANGO



Mango Sofa
95"W x 36"D x 34"H
Trade Show Price: \$941.00



Mango Chair
39"W x 34"D x 34"H
Trade Show Price: \$560.00



Mango Ottoman
28"W x 25"D x 19"H
Trade Show Price: \$319.00

MONACO



Monaco Sofa
84"W x 35"D x 34"H
Trade Show Price: \$1,005.00



Monaco Chair
36"W x 35"D x 34"H
Trade Show Price: \$624.00



Monaco Oval Ottoman
48"W x 24"D x 17"H
Trade Show Price: \$363.00

FABRIC COLLECTIONS

MONTANA MOCHA



Montana Mocha Sofa
79"W x 35"D x 34"H
Trade Show Price: \$630.00



Montana Mocha Loveseat
57"W x 35"D x 34"H
Trade Show Price: \$554.00



Montana Mocha Chair
35"Square x 34"H
Trade Show Price: \$427.00

NIKO



Niko Sofa
81"W x 30"D x 38"H
Trade Show Price: \$828.00



Niko Loveseat
58"W x 30"D x 38"H
Trade Show Price: \$757.00



Niko Chair
31"W x 30"D x 38"H
Trade Show Price: \$630.00

OLIVER



Oliver Sofa
90"W x 34"D x 34"H
Trade Show Price: \$941.00



Oliver Chair
37"W x 34"D x 34"H
Trade Show Price: \$560.00

PENELOPE



Penelope Sofa
96"W x 36"D x 36"H
Trade Show Price: \$941.00



Penelope Chair
35"W x 36"D x 40"H
Trade Show Price: \$560.00



Penelope Ottoman
24"Round x 15"H
Trade Show Price: \$319.00

FABRIC COLLECTIONS

REGALE



Regale Sofa
78"W x 35"D x 39"H
Trade Show Price: \$941.00



Regale Chaise
26"W x 73"D x 39"H
Trade Show Price: \$814.00



Regale Chair
24"W x 22"D x 40"H
Trade Show Price: \$407.00



Regale Bench Ottoman
48"W x 24"D x 18"H
Trade Show Price: \$407.00

SUAVE MIDNIGHT



Suave Midnight Sofa
77"W x 36"D x 33"H
Trade Show Price: \$586.00



Suave Midnight Loveseat
54"W x 36"D x 33"H
Trade Show Price: \$509.00



Suave Midnight Chair
32"W x 36"D x 33"H
Trade Show Price: \$382.00



Suave Midnight Scoop Ottoman
31"W x 25"D x 20"H
Trade Show Price: \$217.00

WINSTON



Winston Sofa
93"W x 39"D x 34"H
Trade Show Price: \$941.00



Winston Chair
47"W x 38"D x 33"H
Trade Show Price: \$542.00



Winston Bench Ottoman
48"W x 24"D x 15"H
Trade Show Price: \$345.00

LEATHER COLLECTIONS

BLANC



Blanc Sofa
75"W x 35"D x 35"H
Trade Show Price: \$814.00



Blanc Loveseat
54"W x 35"D x 35"H
Trade Show Price: \$777.00



Blanc Chair
33"W x 35"D x 35"D
Trade Show Price: \$649.00



Blanc Bench Ottoman
48"W x 24"D x 18"H
Trade Show Price: \$390.00



Blanc Cube Ottoman
17"Square x 17"H
Trade Show Price: \$136.00

BOCA



Boca Armless Chair - Black
22"W x 27"D x 30"H
Trade Show Price: \$415.00



Boca Corner - Black
27"W x 27"D x 30"H
Trade Show Price: \$446.00



Boca Armless Chair - Charged
22"W x 27"D x 30"H
Trade Show Price: \$471.00



Boca Corner - Charged
27"W x 27"D x 30"H
Trade Show Price: \$509.00

**Client responsible for power source.*

**Client responsible for power source.*

CHANDLER



Chandler Sofa
76"W x 37"D x 35"H
Trade Show Price: \$669.00



Chandler Loveseat
53"W x 37"D x 35"H
Trade Show Price: \$644.00



Chandler Chair
31"W x 37"D x 35"H
Trade Show Price: \$503.00



Chandler Bench Ottoman
60"W x 24"D x 17"H
Trade Show Price: \$345.00

LEATHER COLLECTIONS

CONTINENTAL



Continental Curved Loveseat
82"W x 34"D x 31"H
Trade Show Price: \$802.00



Continental Reverse Loveseat
72"W x 34"D x 31"H
Trade Show Price: \$777.00



Continental Curved Bench
70"W x 26"D x 19"H
Trade Show Price: \$407.00



Continental Half Moon Ottoman
33"W x 19"D x 19"H
Trade Show Price: \$345.00



Continental Wedge Ottoman
30"W x 34"D x 19"H
Trade Show Price: \$345.00

CRYSTAL



Crystal Loveseat
75"W x 29"D x 60"H
Trade Show Price: \$846.00



Crystal Bench Loveseat
75"W x 28"D x 31"H
Trade Show Price: \$509.00



Crystal Chaise
72"W x 30"D x 41"H
Trade Show Price: \$802.00



Crystal Round Ottoman
43"Round x 20"H
Trade Show Price: \$542.00



Crystal 6' Bar Surround
80"W x 24"D x 42"H
Trade Show Price: \$269.00

**VIP Glow Bar 6' rental required*



Crystal 8' Bar Surround
104"W x 24"D x 42"H
Trade Show Price: \$306.00

**VIP Glow Bar 6' rental required*



LEATHER COLLECTIONS

ESSENTIALS



Essentials Banquette Flat Top (2 pieces)

60"Round x 19"H

Trade Show Price: \$745.00



Essentials Banquette (2 pieces)

60"Round x 48"H

Trade Show Price: \$1,011.00



Essentials Storage Ottoman

48"W x 24"D x 20"H

Trade Show Price: \$478.00



Essentials Turning Bed (2 pieces)

96"W x 48"D x 36"H

Trade Show Price: \$1,215.00



Essentials Turning Bed - Charged (2 pieces)

96"W x 48"D x 25"H

Trade Show Price: \$1,348.00

**Client responsible for power source.*

FUNCTION



Function Armless Chair

28"Square x 29"H

Trade Show Price: \$415.00



Function Corner

28"Square x 29"H

Trade Show Price: \$446.00

GRAMMERCY



Grammercy Sofa

82"W x 36"D x 36"H

Trade Show Price: \$745.00



Grammercy Loveseat

57"W x 36"D x 36"H

Trade Show Price: \$649.00



Grammercy Chair

28"W x 36"D x 36"H

Trade Show Price: \$415.00



Grammercy Chaise

63"W x 28"D x 36"H

Trade Show Price: \$554.00

LEATHER COLLECTIONS

GRAMMERCY



Grammercy 1/4 Round Ottoman
34"W x 19"D x 17"H
Trade Show Price: \$212.00



Grammercy Banquette
59"Round x 38"H (2 pieces)
Trade Show Price: \$1,011.00



Grammercy Corner
36"Square x 36"H
Trade Show Price: \$478.00



Grammercy Bench Ottoman
60"W x 24"D x 17"H
Trade Show Price: \$345.00



Grammercy Round Ottoman
46"Round x 17"H
Trade Show Price: \$345.00



Grammercy Square Ottoman
40"Square x 17"H
Trade Show Price: \$345.00

METRO



Metro Sofa
85"W x 35"D x 35"H
Trade Show Price: \$669.00



Metro Loveseat
60"W x 35"D x 35"H
Trade Show Price: \$644.00



Metro Chair
35"Square x 35"H
Trade Show Price: \$503.00



Metro Cube Ottoman
18"Square x 18"H
Trade Show Price: \$136.00



Metro Bench Ottoman
60"W x 24"D x 17"H
Trade Show Price: \$345.00



Metro Square Ottoman
40"Square x 17"H
Trade Show Price: \$345.00

LEATHER COLLECTIONS

PARMA



Parma Sofa
79"W x 37"D x 36"H
Trade Show Price: \$669.00



Parma Loveseat
56"W x 37"D x 36"H
Trade Show Price: \$644.00



Parma Chair
33"W x 37"D x 36"H
Trade Show Price: \$503.00



Parma Bench Ottoman
60"W x 24"D x 17"H
Trade Show Price: \$345.00

SOPHISTICATION



Sophistication Sofa
72"W x 31"D x 48"H
Trade Show Price: \$802.00



Sophistication Loveseat
48"W x 31"D x 48"H
Trade Show Price: \$542.00



Sophistication Chair
24"W x 31"D x 48"H
Trade Show Price: \$407.00



Sophistication Corner
31"Square x 48"H
Trade Show Price: \$407.00



Sophistication Ottoman
31"Square x 19"H
Trade Show Price: \$306.00

WHISPER



Whisper Sofa
87"W x 37"D x 35"H
Trade Show Price: \$777.00



Whisper Loveseat
61"W x 37"D x 35"H
Trade Show Price: \$745.00



Whisper Chair
35"W x 37"D x 35"H
Trade Show Price: \$618.00



Whisper Bench Ottoman
60"W x 24"D x 17"H
Trade Show Price: \$345.00

LEATHER COLLECTIONS

WHISPER



Whisper 1/4 Round Ottoman
34"W x 19"D x 17"H
Trade Show Price: \$212.00



Whisper Square Ottoman
40"Square x 17"H
Trade Show Price: \$345.00



Whisper Round Ottoman
46"Round x 17"H
Trade Show Price: \$345.00



Whisper Banquette
59"Round x 38"H (2 pieces)
Trade Show Price: \$1,011.00



Whisper Cube Ottoman
18"Square x 18"H
Trade Show Price: \$136.00

ZEPPELIN



Zeppelin Sectional
128"W x 28"D x 31"H (2 pieces)
Trade Show Price: \$1,684.00

OUTDOOR COLLECTIONS

COSTA



Costa Sofa
83"W x 36"D x 27"H
Trade Show Price: \$840.00



Costa Chair
38"W x 35"D x 26"H
Trade Show Price: \$453.00



Costa Table
41"W x 26"D x 15"H
Trade Show Price: \$262.00

EVOKE



Evoke Sofa
81"W x 35"D x 27"H
Trade Show Price: \$1,011.00



Evoke Chair
33"W x 35"D x 27"H
Trade Show Price: \$542.00



Evoke Cocktail Table
48"W x 24"D x 18"H
Trade Show Price: \$345.00



Evoke End Table
24"W x 28"D x 25"H
Trade Show Price: \$306.00

GRASS



Evoke Cube Ottoman
18"Square x 18"H
Trade Show Price: \$217.00



Grass Loveseat
49"W x 32"D x 48"H
Trade Show Price: \$802.00



Grass Bench Ottoman
48"W x 21"D x 18"H
Trade Show Price: \$554.00

VERONA



Verona Sofa
74"W x 38"D x 25"H
Trade Show Price: \$960.00



Verona Chair
28"W x 38"D x 25"H
Trade Show Price: \$495.00



Verona Ottoman
26"W x 21"D x 18"H
Trade Show Price: \$286.00

CHARGED COLLECTION

Client responsible for power source.



CHARGING CHAIRS



Boca Armless Chair - Charged
22"W x 27"D x 30"H
Trade Show Price: \$471.00



Boca Corner - Charged
27"W x 27"D x 30"H
Trade Show Price: \$509.00



Patrice Tablet Chair - Charged
28"W x 31"D x 31"H
Trade Show Price: \$491.00

CHARGING BENCHES



Essentials Turning Bed - Charged
96"W x 48"D x 25"H
Trade Show Price: \$1,348.00



Lincoln Bench - Charged
59"W x 39"D x 17"H
Trade Show Price: \$745.00

CHARGING TABLES



Conference Table 8' White - Charged
96"W x 43"D x 30"H
Trade Show Price: \$1,062.00



Aspen Cocktail Table - Charged
48"W x 24"D x 18"H
Trade Show Price: \$446.00



Aspen Bar Table - Charged
72"W x 26"D x 42"H
Trade Show Price: \$789.00

SOFAS



Aurora Sofa
90"W x 33"D x 30"H
Trade Show Price: \$941.00



Blanc Sofa
75"W x 35"D x 35"H
Trade Show Price: \$814.00



Chandler Sofa
76"W x 37"D x 35"H
Trade Show Price: \$669.00



Chateau Sofa
82"W x 35"D x 36"H
Trade Show Price: \$941.00



Costa Sofa
83"W x 36"D x 27"H
Trade Show Price: \$840.00



Cromwell Sofa
78"W x 32"D x 29"H
Trade Show Price: \$941.00



Evoke Sofa
81"W x 35"D x 27"H
Trade Show Price: \$1,011.00



Grammery Sofa
82"W x 36"D x 36"H
Trade Show Price: \$745.00



Jade Sofa
82"W x 36"D x 34"H
Trade Show Price: \$777.00



Madison Sofa
86"W x 34"D x 34"H
Trade Show Price: \$777.00



Mango Sofa
95"W x 36"D x 34"H
Trade Show Price: \$941.00



Metro Sofa
85"W x 35"D x 35"H
Trade Show Price: \$669.00



Monaco Sofa
84"W x 35"D x 34"H
Trade Show Price: \$1,005.00



Montana Mocha Sofa
79"W x 35"D x 34"H
Trade Show Price: \$630.00



Niko Sofa
81"W x 30"D x 38"H
Trade Show Price: \$828.00



Oliver Sofa
90"W x 34"D x 34"H
Trade Show Price: \$941.00



Parma Sofa
79"W x 37"D x 36"H
Trade Show Price: \$669.00



Penelope Sofa
96"W x 36"D x 36"H
Trade Show Price: \$941.00



Regale Sofa
78"W x 35"D x 39"H
Trade Show Price: \$941.00



Sophistication Sofa
72"W x 31"D x 48"H
Trade Show Price: \$802.00

SOFAS



Suave Midnight Sofa
77"W x 36"D x 33"H
Trade Show Price: \$586.00



Verona Sofa
74"W x 38"D x 25"H
Trade Show Price: \$960.00



Whisper Sofa
87"W x 37"D x 35"H
Trade Show Price: \$777.00



Winston Sofa
93"W x 39"D x 34"H
Trade Show Price: \$941.00

LOVESEATS



Blanc Loveseat
54"W x 35"D x 35"H
Trade Show Price: \$777.00



Chandler Loveseat
53"W x 37"D x 35"H
Trade Show Price: \$644.00



Continental Curved Loveseat
82"W x 34"D x 31"H
Trade Show Price: \$802.00



Continental Reverse Loveseat
72"W x 34"D x 31"H
Trade Show Price: \$777.00



Crystal Chaise
72"W x 30"D x 41"H
Trade Show Price: \$802.00



Crystal Loveseat
75"W x 29"D x 60"H
Trade Show Price: \$846.00



Grammercy Chaise
63"W x 28"D x 36"H
Trade Show Price: \$554.00



Grammercy Loveseat
57"W x 36"D x 36"H
Trade Show Price: \$649.00



Grass Loveseat
49"W x 32"D x 48"H
Trade Show Price: \$802.00



Metro Loveseat
60"W x 35"D x 35"H
Trade Show Price: \$644.00



Montana Mocha Loveseat
57"W x 35"D x 34"H
Trade Show Price: \$554.00



Niko Loveseat
58"W x 30"D x 38"H
Trade Show Price: \$757.00

LOVESEATS



Parma Loveseat
56"W x 37"D x 36"H
Trade Show Price: \$644.00



Regale Chaise
26"W x 73"D x 39"H
Trade Show Price: \$814.00



Sophistication Loveseat
48"W x 31"D x 48"H
Trade Show Price: \$542.00



Suave Midnight Loveseat
54"W x 36"D x 33"H
Trade Show Price: \$509.00



Whisper Loveseat
61"W x 37"D x 35"H
Trade Show Price: \$745.00

CHAIRS



Aurora Chair
39"W x 33"D x 30"H
Trade Show Price: \$560.00



Bianca Stage Chair
26"Square x 37"H
Trade Show Price: \$297.00



Blanc Chair
33"W x 35"D x 35"D
Trade Show Price: \$649.00



Boca Armless Chair - Black
22"W x 27"D x 30"H
Trade Show Price: \$415.00



Boca Armless Chair - Charged
22"W x 27"D x 30"H
Trade Show Price: \$471.00



Buckskin Stage Chair
25"W x 26"D x 37"H
Trade Show Price: \$249.00



Chamois Stage Chair
25"W x 26"D x 37"H
Trade Show Price: \$249.00



Chandler Chair
31"W x 37"D x 35"H
Trade Show Price: \$503.00

**Client responsible for power source.*

CHAIRS



Costa Chair
38"W x 35"D x 26"H
Trade Show Price: \$453.00



Cromwell Chair
32"W x 32"D x 29"H
Trade Show Price: \$560.00



Dijon Chair
24"W x 29"D x 35"H
Trade Show Price: \$407.00



Elan Chair
30"W x 29"D x 37"H
Trade Show Price: \$407.00



Empire Chair
28"W x 32"D x 32"H
Trade Show Price: \$446.00



Evoke Chair
33"W x 35"D x 27"H
Trade Show Price: \$542.00



Function Armless Chair
28"Square x 29"H
Trade Show Price: \$415.00



Grammercy Chair
28"W x 36"D x 36"H
Trade Show Price: \$415.00



Ibiza Chair
31"W x 35"D x 32"H
Trade Show Price: \$618.00



Jade Chair
32"W x 36"D x 34"H
Trade Show Price: \$453.00



Madison Chair
33"W x 34"D x 34"H
Trade Show Price: \$453.00



Mango Chair
39"W x 34"D x 34"H
Trade Show Price: \$560.00



Marteen Chair
23"Square x 40"H
Trade Show Price: \$407.00



Metro Chair
35"Square x 35"H
Trade Show Price: \$503.00



Midnight Stage Chair
25"W x 26"D x 37"H
Trade Show Price: \$249.00



Monaco Chair
36"W x 35"D x 34"H
Trade Show Price: \$624.00



Monarch Chair
28"Square x 30"H
Trade Show Price: \$285.00



Montana Mocha Chair
35"Square x 34"H
Trade Show Price: \$427.00



Niko Chair
31"W x 30"D x 38"H
Trade Show Price: \$630.00



Oliver Chair
37"W x 34"D x 34"H
Trade Show Price: \$560.00

CHAIRS



Parma Chair
33"W x 37"D x 36"H
Trade Show Price: \$503.00



Patrice Table Chair - Charged
28"W x 31"D x 31"H
Trade Show Price: \$491.00

**Client responsible for power source.*



Penelope Chair
35"W x 36"D x 40"H
Trade Show Price: \$560.00



Regale Chair
24"W x 22"D x 40"H
Trade Show Price: \$407.00



Sophistication Chair
24"W x 31"D x 48"H
Trade Show Price: \$407.00



Suave Midnight Chair
32"W x 36"D x 33"H
Trade Show Price: \$382.00



Tulip Chair
27"W x 26"D x 35"H
Trade Show Price: \$269.00



Verona Chair
28"W x 38"D x 25"H
Trade Show Price: \$495.00



Whisper Chair
35"W x 37"D x 35"H
Trade Show Price: \$618.00



Winston Chair
47"W x 38"D x 33"H
Trade Show Price: \$542.00

OTTOMANS & BENCHES



Blanc Bench Ottoman
48"W x 24"D x 18"H
Trade Show Price: \$390.00



Chandler Bench Ottoman
60"W x 24"D x 17"H
Trade Show Price: \$345.00



Continental Curved Bench
70"W x 26"D x 19"H
Trade Show Price: \$407.00



Continental Half Moon Ottoman
33"W x 19"D x 19"H
Trade Show Price: \$345.00

OTTOMANS & BENCHES



Continental Wedge Ottoman
30"W x 34"D x 19"H
Trade Show Price: \$345.00



Crystal Bench Loveseat
75"W x 28"D x 31"H
Trade Show Price: \$509.00



Crystal Round Ottoman
43"Round x 20"H
Trade Show Price: \$542.00



Element Bench
71"W x 16"D x 18"H
Trade Show Price: \$319.00



Essentials Storage Ottoman
48"W x 24"D x 20"H
Trade Show Price: \$478.00



Fontana Ottoman
18"Square x 18"H
**Special Event Exclusive Item*



Grammercy 1/4 Round Ottoman
34"W x 19"D x 17"H
Trade Show Price: \$212.00



Grammercy Bench Ottoman
60"W x 24"D x 17"H
Trade Show Price: \$345.00



Grammercy Round Ottoman
46"Round x 17"H
Trade Show Price: \$345.00



Grammercy Square Ottoman
40"Square x 17"H
Trade Show Price: \$345.00



Grass Ottoman
48"W x 21"D x 18"H
Trade Show Price: \$554.00



Jade Bench Ottoman
48"W x 24"D x 19"H
Trade Show Price: \$345.00



Lincoln Bench - Charged
59"W x 39"D x 17"H
Trade Show Price: \$745.00



Luxe Almond Brittle Ottoman
60"W x 30"D x 27"H
Trade Show Price: \$1,210.00



Luxe California Wine Ottoman
50"Square x 20"H
Trade Show Price: \$1,287.00



Luxe Chartreuse Ottoman
90"W x 20"D x 20"H
Trade Show Price: \$1,210.00



Luxe Victory Blue Ottoman
80"W x 40"D x 20"H
Trade Show Price: \$2,043.00



Madison Bench - Sky
48"W x 24"D x 17"H
Trade Show Price: \$319.00



Madison Ottomon - Apricot
24"Square x 17"H
Trade Show Price: \$204.00



Madison Ottoman - Sand Dollar
24"Square x 17"H
Trade Show Price: \$204.00

OTTOMANS & BENCHES



Madison Ottoman - Sunflower
24"Square x 17"H
Trade Show Price: \$204.00



Madison Ottoman - Willow
24"Square x 17"H
Trade Show Price: \$204.00



Mango Ottoman
28"W x 25"D x 19"H
Trade Show Price: \$319.00



Metro Bench Ottoman
60"W x 24"D x 17"H
Trade Show Price: \$345.00



Metro Square Ottoman
40"Square x 17"H
Trade Show Price: \$345.00



Monaco Oval Ottoman
48"W x 24"D x 17"H
Trade Show Price: \$363.00



Parma Bench Ottoman
60"W x 24"D x 17"H
Trade Show Price: \$345.00



Penelope Ottoman
24"Round x 15"H
Trade Show Price: \$319.00



Regale Bench Ottoman
48"W x 24"D x 18"H
Trade Show Price: \$407.00



Sophistication Ottoman
31"Square x 19"H
Trade Show Price: \$306.00



Suave Midnight Scoop Ottoman
31"W x 25"D x 20"H
Trade Show Price: \$217.00



Verona Ottoman
26"W x 21"D x 18"H
Trade Show Price: \$286.00



Whisper 1/4 Round Ottoman
34"W x 19"D x 17"H
Trade Show Price: \$212.00



Whisper Bench Ottoman
60"W x 24"D x 17"H
Trade Show Price: \$345.00



Whisper Round Ottoman
46"Round x 17"H
Trade Show Price: \$345.00



Whisper Square Ottoman
40"Square x 17"H
Trade Show Price: \$345.00



Winston Bench Ottoman
48"W x 24"D x 15"H
Trade Show Price: \$345.00

CUBE OTTOMANS



Benton Cube Ottoman - Blue
17"Square x 18"H
Trade Show Price: \$136.00



Benton Cube Ottoman - Bronze
17"Square x 18"H
Trade Show Price: \$136.00



Benton Cube Ottoman - Gold
17"Square x 18"H
Trade Show Price: \$136.00



Benton Cube Ottoman - Silver
17"Square x 18"H
Trade Show Price: \$136.00



Blanc Cube Ottoman
17"Square x 17"H
Trade Show Price: \$136.00



Evoke Cube Ottoman
18"Square x 18"H
Trade Show Price: \$217.00



Luxe Hot Pink Cube Ottoman
20"Square x 20"H
Trade Show Price: \$455.00



Luxe Tropical Splash Cube Ottoman
20"Square x 20"H
Trade Show Price: \$455.00



Metro Cube Ottoman
18"Square x 18"H
Trade Show Price: \$136.00



Udder Madness Cube Ottoman
18"Square x 18"H
Trade Show Price: \$136.00



Vinyl Cube Ottoman - Blue
18"Square x 18"H
Trade Show Price: \$136.00



Vinyl Cube Ottoman - Green
18"Square x 18"H
Trade Show Price: \$136.00



Vinyl Cube Ottoman - Purple
18"Square x 18"H
Trade Show Price: \$136.00



Vinyl Cube Ottoman - Red
18"Square x 18"H
Trade Show Price: \$136.00



Whisper Cube Ottoman
18"Square x 18"H
Trade Show Price: \$136.00



Zambia Cube Ottoman
18"Square x 18"H
Trade Show Price: \$136.00

BANQUETTES & TURNING BEDS



Essentials Banquette Flat Top (2 pieces)
60"Round x 19"H
Trade Show Price: \$745.00



Essentials Banquette (2 pieces)
60"Round x 48"H
Trade Show Price: \$1,011.00



Essentials Turning Bed (2 pieces)
96"W x 48"D x 36"H
Trade Show Price: \$1,215.00



Essentials Turning Bed - Charged (2 pieces)
96"W x 48"D x 25"H
Trade Show Price: \$1,348.00

**Client responsible for power source.*



Grammercy Banquette
59"Round x 38"H (2 pieces)
Trade Show Price: \$1,011.00



Whisper Banquette
59"Round x 38"H (2 pieces)
Trade Show Price: \$1,011.00

CAFÉ & DINING CHAIRS



Caprice Chair
25"W x 24"D x 32"H
Trade Show Price: \$136.00



Clara Chair
18"W x 21"D x 35"H
Trade Show Price: \$153.00



Colin Chair
22"W x 19"D x 33"H
Trade Show Price: \$136.00



Criss Cross Chair
17"W x 21"D x 35"H
Trade Show Price: \$153.00



Elio Chair
17"Square x 33"H
Trade Show Price: \$136.00



Escape Chair
17"W x 16"D x 32"H
Trade Show Price: \$136.00



Ghost Chair
21"Square x 37"H
Trade Show Price: \$153.00



Leslie Chair
17"W x 21"D x 31"H
Trade Show Price: \$121.00

CAFÉ & DINING CHAIRS



Milo Chair - Black
20"W x 22"D x 33"H
Trade Show Price: \$134.00



Milo Chair - California Wine
20"W x 22"D x 33"H
Trade Show Price: \$134.00



Milo Chair - Chartreuse
20"W x 22"D x 33"H
Trade Show Price: \$134.00



Milo Chair - Chocolate
20"W x 22"D x 33"H
Trade Show Price: \$134.00



Milo Chair - Jade
20"W x 22"D x 33"H
Trade Show Price: \$134.00



Milo Chair - Victory Blue
20"W x 22"D x 33"H
Trade Show Price: \$134.00



Milo Chair - White
20"W x 22"D x 33"H
Trade Show Price: \$134.00



Nexus Chair
19"W x 22"D x 32"H
Trade Show Price: \$161.00



Regal Dining Chair
19"W x 23"D x 38"H
Trade Show Price: \$192.00



Silk Back Armless Chair - Black
17"W x 18"D x 34"H
Trade Show Price: \$136.00



Silk Back Armless Chair - Blue
17"W x 18"D x 34"H
Trade Show Price: \$136.00



Silk Back Armless Chair - Green
17"W x 18"D x 34"H
Trade Show Price: \$136.00



Silk Back Armless Chair - Purple
17"W x 18"D x 34"H
Trade Show Price: \$136.00



Silk Back Armless Chair - Red
17"W x 18"D x 34"H
Trade Show Price: \$136.00



Silk Back Armless Chair - White
17"W x 18"D x 34"H
Trade Show Price: \$136.00



Sonic Chair
20"W x 21"D x 32"H
Trade Show Price: \$136.00



Vienna Chair - Orange
21"Square x 32"H
Trade Show Price: \$161.00



Vienna Chair - Smoke Grey
21"Square x 32"H
Trade Show Price: \$161.00



Vienna Chair - Teal
21"Square x 32"H
Trade Show Price: \$161.00

BAR STOOLS



Caprice Stool
25"W x 26"D x 44"H
Trade Show Price: \$237.00



Clara Stool
17"W x 21"D x 41"H
Trade Show Price: \$229.00



Colin Stool
20"W x 19"D x 46"H
Trade Show Price: \$192.00



Criss Cross Stool
15"W x 19"D x 41"H
Trade Show Price: \$229.00



Equino Stool
15"W x 13"D x 35"H
Trade Show Price: \$237.00



Escape Stool
16"Square x 41"H
Trade Show Price: \$192.00



Euro Stool
22"W x 24"D x 42"H
Trade Show Price: \$217.00



Ghost Stool
18"Square (at footbase) x 30"H
Trade Show Price: \$192.00



Hourglass Stool
18"W x 20"D x 43"H
Trade Show Price: \$237.00



Marcus Bar Stool
17"W (at footbase) x 29"H
Trade Show Price: \$173.00



Milo Stool - Black
20"W x 21"D x 41"H
Trade Show Price: \$217.00



Milo Stool - California Wine
20"W x 21"D x 41"H
Trade Show Price: \$217.00



Milo Stool - Chartreuse
20"W x 21"D x 41"H
Trade Show Price: \$217.00



Milo Stool - Chocolate
20"W x 21"D x 41"H
Trade Show Price: \$217.00



Milo Stool - Jade
20"W x 21"D x 41"H
Trade Show Price: \$217.00



Milo Stool - Victory Blue
20"W x 21"D x 41"H
Trade Show Price: \$217.00



Milo Stool - White
20"W x 21"D x 41"H
Trade Show Price: \$217.00



Nexus Stool
19"W x 20"D x 44"H
Trade Show Price: \$198.00



Regal Stool
19"W x 24"D x 45"H
Trade Show Price: \$237.00



Silk Back Stool - Black
17"W x 18"D x 42"H
Trade Show Price: \$217.00

BAR STOOLS



Silk Back Stool - Blue
17"W x 18"D x 42"H
Trade Show Price: \$217.00



Silk Back Stool - Green
17"W x 18"D x 42"H
Trade Show Price: \$217.00



Silk Back Stool - Purple
17"W x 18"D x 42"H
Trade Show Price: \$217.00



Silk Back Stool - Red
17"W x 18"D x 42"H
Trade Show Price: \$217.00



Silk Back Stool - White
17"W x 18"D x 42"H
Trade Show Price: \$217.00



Sonic Stool
22"W x 23"D x 42"H
Trade Show Price: \$192.00



Vienna Stool - Orange
17"Square x 39"H
Trade Show Price: \$255.00



Vienna Stool - Smoke Grey
17"Square x 39"H
Trade Show Price: \$255.00



Vienna Stool - Teal
17"Square x 39"H
Trade Show Price: \$255.00

TABLES

BAR TABLES



24" Square Bar Table with Black Base - White
24"Square x 42"H
Trade Show Price: \$242.00



24" Square Bar with Chrome Base - White
24"Square x 42"H
Trade Show Price: \$242.00



24" Square Bar Table with Tulip Base - White
24"Square x 42"H
Trade Show Price: \$281.00



30" Round Bar Table with Black Base - Black
30"Round x 42"H
Trade Show Price: \$242.00

TABLES

BAR TABLES



**30" Round Bar Table
with Chrome Base - Black**
30"Round x 42"H
Trade Show Price: \$242.00



**30" Round Bar Table
with Tulip Base - Black**
30"Round x 42"H
Trade Show Price: \$281.00



**30" Round Bar Table
with Black Base - Maple**
30"Round x 42"H
Trade Show Price: \$242.00



**30" Round Bar Table
with Chrome Base - Maple**
30"Round x 42"H
Trade Show Price: \$242.00



**30" Round Bar Table
with Tulip Base - Maple**
30"Round x 42"H
Trade Show Price: \$281.00



**30" Round Bar Table
with Black Base - White**
30"Round x 42"H
Trade Show Price: \$242.00



**30" Round Bar Table
with Chrome Base - White**
30"Round x 42"H
Trade Show Price: \$242.00



**30" Round Bar Table
with Tulip Base - White**
30"Round x 42"H
Trade Show Price: \$281.00



**32" Round Bar Table
with Black Base - Walnut**
32"Round x 42"H
Trade Show Price: \$345.00



**32" Round Bar Table
with Chrome Base - Walnut**
32"Round x 42"H
Trade Show Price: \$345.00



**32" Round Bar Table
with Tulip Base - Walnut**
32"Round x 42"H
Trade Show Price: \$382.00



**36" Round Bar Table
with Black Base - Black**
36"Round x 42"H
Trade Show Price: \$249.00



**36" Round Bar Table
with Chrome Base - Black**
36"Round x 42"H
Trade Show Price: \$249.00



**36" Round Bar Table
with Black Base - Maple**
36"Round x 42"H
Trade Show Price: \$249.00



**36" Round Bar Table
with Chrome Base - Maple**
36"Round x 42"H
Trade Show Price: \$249.00



**36" Round Bar Table
with Black Base - White**
36"Round x 42"H
Trade Show Price: \$249.00

TABLES

BAR TABLES



36" Round Bar Table with Chrome Base - White
36"Round x 42"H
Trade Show Price: \$249.00



6' Rectangle Bar Table with Black Base
72"W x 24"D x 42"H
Trade Show Price: \$376.00



6' Rectangle Bar Table with Chrome Base
72"W x 24"D x 42"H
Trade Show Price: \$376.00



6' Rectangle Bar Table with Tulip Base
72"W x 24"D x 42"H
Trade Show Price: \$451.00



Aspen Bar Table - Black
72"W x 26"D x 42"H
Trade Show Price: \$675.00



Aspen Bar Table - Charged
72"W x 26"D x 42"H
Trade Show Price: \$789.00



Aspen Bar Table - Maple
72"W x 26"D x 42"H
Trade Show Price: \$675.00



Aspen Bar Table - White
72"W x 26"D x 42"H
Trade Show Price: \$675.00

**Client responsible for power source*



Ava Bar Table
32"Round x 42"H
Trade Show Price: \$466.00



Chardonnay Bar Table
31"Round x 42"H
Trade Show Price: \$345.00



Club Bar Table
36"Square x 42"H
Trade Show Price: \$669.00



Cylinder Bar Table 30"
22"Round x 42"H (cylinder)
30"Round (top)
Trade Show Price: \$407.00



Cylinder Bar Table 42"
22"Round x 42"H (cylinder)
42"Round (top)
Trade Show Price: \$586.00



Cylinder Buffet Table 4'
22"Round x 42"H (cylinders)
48"W x 24"D (top)
Trade Show Price: \$618.00



Cylinder Buffet Table 6'
22"Round x 42"H (cylinders)
72"W x 24"D (top)
Trade Show Price: \$669.00



Fuze Bar Table
36"Square x 42"H
Trade Show Price: \$274.00

TABLES

BAR TABLES



Hourglass Bar Table
36"Round x 42"H
Trade Show Price: \$415.00



Java Bar Table
30"Round x 42"H
Trade Show Price: \$407.00



LED Acrylic High Top Table
17"Square x 42"H (base)
30"Square (top)
Trade Show Price: \$542.00



LED Acrylic Pedestal
17"Square x 42"H
Trade Show Price: \$542.00



Memphis Rectangle Bar Table
66"W x 28"D x 42"H
Trade Show Price: \$712.00



Memphis Square Bar Table
38"Square x 42"H
Trade Show Price: \$586.00



Spectrum Bar Table - Blue
24"Square x 42"H
Trade Show Price: \$262.00



Spectrum Bar Table - Green
24"Square x 42"H
Trade Show Price: \$262.00



Spectrum Bar Table - Purple
24"Square x 42"H
Trade Show Price: \$262.00



Spectrum Bar Table - Red
24"Square x 42"H
Trade Show Price: \$262.00



Spectrum Bar Table with Tulip Base - Blue
24"Square x 42"H
Trade Show Price: \$300.00



Spectrum Bar Table with Tulip Base - Green
24"Square x 42"H
Trade Show Price: \$300.00



Spectrum Bar Table with Tulip Base - Purple
24"Square x 42"H
Trade Show Price: \$300.00



Spectrum Bar Table with Tulip Base - Red
24"Square x 42"H
Trade Show Price: \$300.00



Zinc Bar Table
24"Round x 42"H
Trade Show Price: \$363.00

TABLES

CAFÉ TABLES



24" Square Café Table with Black Base - White
24"Square x 30"H
Trade Show Price: \$242.00



24" Square Café Table with Chrome Base - White
24"Square x 30"H
Trade Show Price: \$242.00



30" Round Café Table with Black Base - Black
30"Round x 30"H
Trade Show Price: \$242.00



30" Round Café Table with Chrome Base - Black
30"Round x 30"H
Trade Show Price: \$242.00



30" Round Café Table with Black Base - Maple
30"Round x 30"H
Trade Show Price: \$242.00



30" Round Café Table with Chrome Base - Maple
30"Round x 30"H
Trade Show Price: \$242.00



30" Round Café Table with Black Base - White
30"Round x 30"H
Trade Show Price: \$242.00



30" Round Café Table with Chrome Base - White
30"Round x 30"H
Trade Show Price: \$242.00



32" Round Café Table with Black Base - Walnut
32"Round x 30"H
Trade Show Price: \$345.00



32" Round Café Table with Chrome Base - Walnut
32"Round x 30"H
Trade Show Price: \$345.00



36" Round Café Table with Black Base - Black
36"Round x 30"H
Trade Show Price: \$249.00



36" Round Café Table with Chrome Base - Black
36"Round x 30"H
Trade Show Price: \$249.00



36" Round Café Table with Black Base - Maple
36"Round x 30"H
Trade Show Price: \$249.00



36" Round Café Table with Chrome Base - Maple
36"Round x 30"H
Trade Show Price: \$249.00



36" Round Café Table with Black Base - White
36"Round x 30"H
Trade Show Price: \$249.00



36" Round Café Table with Chrome Base - White
36"Round x 30"H
Trade Show Price: \$249.00

TABLES

CAFÉ TABLES



6' Rectangle Café Table with Black Base
72"W x 24"D x 30"H
Trade Show Price: \$376.00



6' Rectangle Café Table with Chrome Base
72"W x 24"D x 30"H
Trade Show Price: \$376.00



Cylinder Café Table 42"
42"Round x 30"H (base)
42" Round (top)
Trade Show Price: \$586.00



Cylinder Dining Table
22"Round x 30"H (cylinders)
72"W x 36"D (top)
Trade Show Price: \$669.00



Fuze Café Table
36"Square x 30"H
Trade Show Price: \$274.00



Spectrum Café Table - Blue
24"Square x 30"H
Trade Show Price: \$262.00



Spectrum Café Table - Green
24"Square x 30"H
Trade Show Price: \$262.00



Spectrum Café Table - Purple
24"Square x 30"H
Trade Show Price: \$262.00



Spectrum Café Table - Red
24"Square x 30"H
Trade Show Price: \$262.00

DINING TABLES



Aspen Dining Table
72"W x 30"D x 30"H
Trade Show Price: \$579.00



Brio Dining Table
96"W x 48"D x 30"H
Trade Show Price: \$777.00



Brooklyn Rectangle Dining Table
60"W x 36"D x 30"H
Trade Show Price: \$497.00



Brooklyn Round Dining Table
42"Round x 30"H
Trade Show Price: \$390.00

TABLES

DINING TABLES



Club Dining Table
72"W x 36"D x 30"H
Trade Show Price: \$802.00

**Includes built in Wireless LED Lighting*



Element Dining Table
79"W x 39"D x 30"H
Trade Show Price: \$592.00



Java Dining Table
42"Round x 30"H
Trade Show Price: \$415.00



Tahoe Dining Table
96"W x 48"D x 30"H
Trade Show Price: \$878.00



Vivid Rectangular Dining Table
60"W x 36"D x 30"H
Trade Show Price: \$478.00



Vivid Square Dining Table
42"Square x 30"H
Trade Show Price: \$415.00

COCKTAIL TABLES



Aria Cocktail Table - Blue
44"W x 20"D x 18"H
Trade Show Price: \$255.00



Aria Cocktail Table - Charcoal
44"W x 20"D x 18"H
Trade Show Price: \$255.00



Aria Cocktail Table - Green
44"W x 20"D x 18"H
Trade Show Price: \$255.00



Aria Cocktail Table - Purple
44"W x 20"D x 18"H
Trade Show Price: \$255.00



Aria Cocktail Table - Red
44"W x 20"D x 18"H
Trade Show Price: \$255.00



Aria Cocktail Table - White
44"W x 20"D x 18"H
Trade Show Price: \$255.00



Aspen Cocktail Table - Charged
48"W x 24"D x 18"H
Trade Show Price: \$446.00
**Client responsible for power source*



Ava Cocktail Table
40"Round x 16"H
Trade Show Price: \$345.00

TABLES

COCKTAIL TABLES



Brooklyn Rectangle Cocktail Table
42"W x 24"D x 16"H
Trade Show Price: \$249.00



Brooklyn Round Cocktail Table
30"Round x 16"H
Trade Show Price: \$249.00



Civic Cocktail Table
44"W x 24"D x 15"H
Trade Show Price: \$294.00



Club Cocktail Table
44"W x 22"D x 18"H
Trade Show Price: \$345.00

**Includes built in Wireless LED Lighting*



Costa Cocktail Table
41"W x 26"D x 15"H
Trade Show Price: \$262.00



Cube Cocktail Table - Black
24"Square x 16"H
Trade Show Price: \$242.00



Evoke Cocktail Table
48"W x 24"D x 18"H
Trade Show Price: \$345.00



Fuze Cocktail Table
40"Square x 16"H
Trade Show Price: \$294.00



Greystone Cocktail Table
50"W x 30"D x 17"H
Trade Show Price: \$294.00



London Cocktail Table
40"Square x 16"H
Trade Show Price: \$294.00



Novel Cocktail Table
46"W x 15"D x 16"H
Trade Show Price: \$345.00



Pentagram Cocktail Table
40"Round x 13.5"H
Trade Show Price: \$294.00



Quasar Cocktail Table
40"Round x 16.5"H
Trade Show Price: \$294.00



Shoreline Cocktail Table
42"W x 24"D x 18"H
Trade Show Price: \$324.00



Tribeca Cocktail Table
48"W x 28"D x 19"H
Trade Show Price: \$255.00



Vivid Cocktail Table
50"W x 24"D x 16"H
Trade Show Price: \$255.00

TABLES

CONSOLE TABLES



Aria Console Table - Charcoal
44"W x 20"D x 30"H
Trade Show Price: \$269.00



Aria Console Table - White
44"W x 20"D x 30"H
Trade Show Price: \$269.00



Fuze Console Table
60"W x 16"D x 34"H
Trade Show Price: \$319.00



Greystone Console Table
50"W x 16"D x 29"H
Trade Show Price: \$319.00



London Console Table
60"W x 16"D x 34"H
Trade Show Price: \$319.00



Tribeca Console Table
48"W x 18"D x 30"H
Trade Show Price: \$269.00



Vivid Console Table
50"W x 24"D x 30"H
Trade Show Price: \$269.00

END TABLES



Aria End Table - Blue
24"W x 20"D x 22"H
Trade Show Price: \$242.00



Aria End Table - Charcoal
24"W x 20"D x 22"H
Trade Show Price: \$242.00



Aria End Table - Green
24"W x 20"D x 22"H
Trade Show Price: \$242.00



Aria End Table - Purple
24"W x 20"D x 22"H
Trade Show Price: \$242.00



Aria End Table - Red
24"W x 20"D x 22"H
Trade Show Price: \$242.00



Aria End Table - White
24"W x 20"D x 22"H
Trade Show Price: \$242.00



Ava End Table
22"Round x 24"H
Trade Show Price: \$306.00



Brooklyn Round End Table
20"Round x 20"H
Trade Show Price: \$242.00

TABLES

END TABLES



Brooklyn Square End Table
22"Square x 20"H
Trade Show Price: \$224.00



Civic End Table
20"Square x 18"H
Trade Show Price: \$249.00



Club End Table
22"Square x 18"H
Trade Show Price: \$306.00

**Includes built-in Wireless LED lighting*



Cube End Table - Black
24"Square x 21"H
Trade Show Price: \$249.00



Evoke End Table
24"W x 28"D x 25"H
Trade Show Price: \$306.00



Fuze End Table
24"Square x 23"H
Trade Show Price: \$262.00



Greystone End Table
22"Square x 23"H
Trade Show Price: \$262.00



London End Table
24"Square x 23"H
Trade Show Price: \$262.00

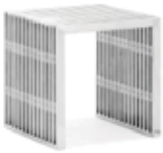

Novel End Table
15"Square x 16"H
Trade Show Price: \$306.00



Pentagram End Table
20"Round x 21"H
Trade Show Price: \$262.00



Quasar End Table
17"Round x 20"H
Trade Show Price: \$262.00



Shoreline End Table
20"Square x 22"H
Trade Show Price: \$286.00



Tribeca End Table
24"W x 28"D x 22"H
Trade Show Price: \$242.00



Vivid End Table
26"Square x 21"H
Trade Show Price: \$242.00

TABLES

ACCENT TABLES



Azaria Accent Table
16"Round x 18"H
Trade Show Price: \$269.00



Eden Accent Table - Large
14"Square x 28"H
Trade Show Price: \$212.00



Eden Accent Table - Small
14"Square x 18"H
Trade Show Price: \$192.00



Fuze Pedestal
16"Square x 44"H
Trade Show Price: \$274.00



Hex Table
18"Round x 20"H
Trade Show Price: \$269.00



Hylton Tablet Table
18"W x 12"D x 28"H
Trade Show Price: \$217.00



Java Accent Table
20"Round x 24"H
Trade Show Price: \$224.00



London Pedestal
16"Square x 44"H
Trade Show Price: \$274.00



Mon End Table
18"Round x 24"H
Trade Show Price: \$173.00



Oro Mirrored Cube
18"Square x 18"H
Trade Show Price: \$161.00



Oyster Accent Table
16"Round x 18"H
Trade Show Price: \$269.00



Phoebe Table - Gold
17"Round x 22"H
Trade Show Price: \$161.00



Phoebe Table - Hazelnut
17"Round x 22"H
Trade Show Price: \$161.00



Phoebe Table - Lime Green
17"Round x 22"H
Trade Show Price: \$161.00



Phoebe Table - Rose
17"Round x 22"H
Trade Show Price: \$161.00



Phoebe Table - Teal
17"Round x 22"H
Trade Show Price: \$161.00



Phoebe Table - Yellow
17"Round x 22"H
Trade Show Price: \$161.00



Porto Accent Table
16"Round x 18"H
Trade Show Price: \$269.00



Reagan Accent Table
22"Round x 23"H
Trade Show Price: \$224.00

TABLES

ACCENT TABLES



Rose Table
17"Round x 17"H
Trade Show Price: \$269.00



Sirona Accent Table
18"W x 12"D x 28"H
Trade Show Price: \$217.00



Woodland Large Pedestal
12"Square x 37"H
Trade Show Price: \$204.00



Woodland Medium Pedestal
12"Square x 28"H
Trade Show Price: \$186.00



Woodland Small Pedestal
12"Square x 20"H
Trade Show Price: \$173.00



Zanzibar Table
17"Square x 17"H
Trade Show Price: \$269.00

LIGHTED

All items are available in variety of colors through wireless LEDs powered by a wireless remote control.



Club Dining Table
72"W x 36"D x 30"H
Trade Show Price: \$802.00



Club Bar Table
36"Square x 42"H
Trade Show Price: \$669.00



Club Cocktail Table
44"W x 22"D x 18"H
Trade Show Price: \$345.00



Club End Table
22"Square x 18"H
Trade Show Price: \$306.00



Cylinder Bar Table 30"
22"Round x 42"H (cylinder)
30"Round (top)
Trade Show Price: \$407.00



Cylinder Bar Table 42"
22"Round x 42"H (cylinder)
42"Round (top)
Trade Show Price: \$586.00



Cylinder Buffet Table 4'
22"Round x 42"H (cylinders)
48"W x 24"D (top)
Trade Show Price: \$618.00



Cylinder Buffet Table 6'
22"Round x 42"H (cylinders)
72"W x 24"D (top)
Trade Show Price: \$669.00

LIGHTED

All items are available in variety of colors through wireless LEDs powered by a wireless remote control.



Cylinder Café Table 42"
22"Round x 30"H (cylinder)
42"Round (top)
Trade Show Price: \$586.00



Cylinder Dining Table
22"Round x 30"H (cylinders)
72"W x 36"D (top)
Trade Show Price: \$669.00



Cylinder End Table
22"Round x 18"H
Trade Show Price: \$269.00



Hourglass Bar Table
36"Round x 42"H
Trade Show Price: \$415.00



LED Acrylic High Top Table
17"Square x 42"H (base)
30"Square (top)
Trade Show Price: \$542.00

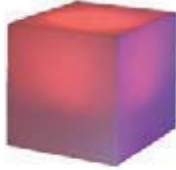

Light Cube
18"Square x 18"H
Trade Show Price: \$269.00



VIP Glow Bar 4**
48"W x 24"D x 42"H (Bar)
13"D x 18"H (Shelf)
Trade Show Price: \$745.00



VIP Glow Bar 6**
72"W x 24"D x 42"H (Bar)
13"D x 18"H (Shelf)
Trade Show Price: \$884.00



VIP Glow Bar 8**
96"W x 24"D x 42"H (Bar)
13"D x 18"H (Shelf)
Trade Show Price: \$1,011.00



VIP Glow Bar Corner*
24"Square x 42"H
Trade Show Price: \$415.00



VIP Glow Bar Curve*
86"W x 24"D x 42"H
Trade Show Price: \$1,152.00

*VIP Glow Bars have the ability to be custom branded.

BARS & BAR BACKS

BARS



Agile Bar
48"W x 16"D x 42"H
Trade Show Price: \$407.00



Crystal Bar Surround for 6' VIP Bar*
80"W x 24"D x 42"H
Trade Show Price: \$269.00



Crystal Bar Surround for 8' VIP Bar*
104"W x 24"D x 42"H
Trade Show Price: \$306.00



Meridian Bar - Harlequin Silver
88"W x 24"D x 42"H
Trade Show Price: \$1,152.00
**Includes LED lighting*



Meridian Bar - Wave White
88"W x 24"D x 42"H
Trade Show Price: \$1,152.00
**Includes LED lighting*



Noir Bar - Bubble Black
72"W x 24"D x 43"H
Trade Show Price: \$1,152.00



Noir Bar - Gatsby Gold
72"W x 24"D x 43"H
Trade Show Price: \$1,152.00



Provence Bar
72"W x 24"D x 42"H
Trade Show Price: \$1,011.00



Umber Bar 6'
72"W x 24"D x 42"H
Trade Show Price: \$884.00



VIP Glow Bar 4'***
48"W x 24"D x 42"H (Bar)
13"D x 18"H (Shelf)
Trade Show Price: \$745.00



VIP Glow Bar 6'*
72"W x 24"D x 42"H (Bar)
13"D x 18"H (Shelf)
Trade Show Price: \$884.00



VIP Glow Bar 8'*
96"W x 24"D x 42"H (Bar)
13"D x 18"H (Shelf)
Trade Show Price: \$1,011.00



VIP Glow Bar Corner*
24"Square x 42"H
Trade Show Price: \$415.00



VIP Glow Bar Curve*
86"W x 24"D x 42"H
Trade Show Price: \$1,152.00

*VIP Glow Bars have the ability to be custom branded.

BARS & BAR BACKS

BAR BACKS



Blox Bar Back
30"W x 16"D x 86"H
Trade Show Price: \$509.00
**Please inquire for shelf dimensions*

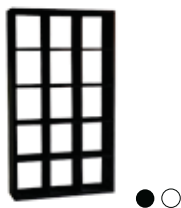

Piazza Bar Back
44"W x 12"D x 79"H
13"W x 14"H (Shelf)
Trade Show Price: \$478.00



Provence Bar Back - Large
36"W x 18"D x 84"H
Trade Show Price: \$814.00
**Please inquire for shelf dimensions*



Provence Bar Back - Small
36"W x 14"D x 75"H
Trade Show Price: \$675.00
**Please inquire for shelf dimensions*

ACCENTS

PATTERN ACCENT PILLOWS



Abstract Magenta
16"Square
Trade Show Price: \$46.00



Deco Gold
16"Square
Trade Show Price: \$46.00



Hybrid Paradise
16"Square
Trade Show Price: \$46.00



Damask
16"Square
Trade Show Price: \$46.00



Jelly Rose
16"Square
Trade Show Price: \$46.00

SOLID ACCENT PILLOWS



Baby Pink
16"Square
Trade Show Price: \$46.00



Black
16"Square
Trade Show Price: \$46.00



Chocolate Brown
16"Square
Trade Show Price: \$46.00



Fiery Orange
16"Square
Trade Show Price: \$46.00

ACCENTS

SOLID ACCENT PILLOWS



Fuchsia
16"Square
Trade Show Price: \$46.00



Gold
16"Square
Trade Show Price: \$46.00



Gunmetal
16"Square
Trade Show Price: \$46.00



Lime Green
16"Square
Trade Show Price: \$46.00



Maize Yellow
16"Square
Trade Show Price: \$46.00



Purple
16"Square
Trade Show Price: \$46.00



Red
16"Square
Trade Show Price: \$46.00



Royal Blue
16"Square
Trade Show Price: \$46.00



Silver
16"Square
Trade Show Price: \$46.00



Turquoise
16"Square
Trade Show Price: \$46.00



White
16"Square
Trade Show Price: \$46.00

TEXTURED ACCENT PILLOWS



Celina Pillow
18"Square
Trade Show Price: \$46.00



Kirby Pillow
18"Square
Trade Show Price: \$46.00



Onyx
18"Square
Trade Show Price: \$46.00



Platinum
18"Square
Trade Show Price: \$46.00



Sapphire
18"Square
Trade Show Price: \$46.00



Topaz
18"Square
Trade Show Price: \$46.00

ACCENTS

BENTON ACCENT PILLOWS



Benton Pillow - Blue
17"Square
Trade Show Price: \$46.00



Benton Pillow - Bronze
17"Square
Trade Show Price: \$46.00



Benton Pillow - Gold
17"Square
Trade Show Price: \$46.00



Benton Pillow - Silver
17"Square
Trade Show Price: \$46.00

LUXE ACCENT PILLOWS



Luxe Pillow - Chartreuse
17"Square
Trade Show Price: \$46.00



Luxe Pillow - Grape
17"Square
Trade Show Price: \$46.00



Luxe Pillow - Tropical Splash
17"Square
Trade Show Price: \$46.00

RUGS



Athens Rug
5'7"W x 7'6"L
Trade Show Price: \$523.00



Cow Hide Rug
5-6'W x 7-8'L (sizes vary)
Trade Show Price: \$478.00

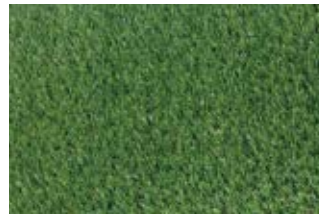

Grass Rug
5'W x 8'L
Trade Show Price: \$478.00



Illusions Black Rug
5'W x 7'6"L
Trade Show Price: \$478.00



Illusions Gray Rug
5'W x 7'6"L
Trade Show Price: \$478.00

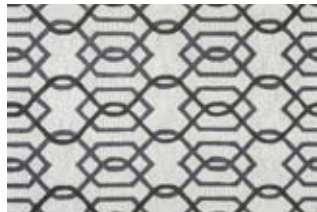

Linq Rug
12'W x 15'L
Trade Show Price: \$669.00



Marrakesh Rug
5'7"W x 7'6"L
Trade Show Price: \$523.00



Mod Rug
5'7"W x 7'6"L
Trade Show Price: \$523.00

ACCENTS

RUGS



Paradigm Rug
12'W x 15'L
Trade Show Price: \$669.00



Pearl Rug
5'7"W x 7'6"L
Trade Show Price: \$478.00



Red Carpet
20'L x 5'W
35'L x 5'W
50'L x 5'W
Stanchions
41"H
Ropes
6'L

Event Price:
20'L x 5'W / \$182.00
35'L x 5'W / \$213.00
50'L x 5'W / \$242.00
Stanchions
41"H / \$22.00
Ropes
6'L / \$4.00

Trade Show Price:
20'L x 5'W / \$345.00
35'L x 5'W / \$415.00
50'L x 5'W / \$478.00
Stanchions - Chrome
41"H / \$77.00
Ropes - Red
6'L / \$40.00



Sawyer Rug
12'W x 15'L
Trade Show Price: \$669.00

DIVIDER WALLS

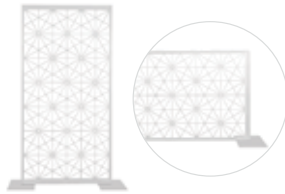

Blaze Divider Wall
8'H x 1"D x 4'W or
4'H x 1"D x 8'W
Trade Show Price: \$508.00

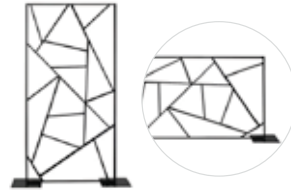

Corbin Divider Wall
8'H x 1"D x 4'W or
4'H x 1"D x 8'W
Trade Show Price: \$508.00

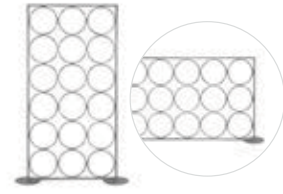

Vortex Divider Wall
8'H x 1"D x 4'W or
4'H x 1"D x 8'W
Trade Show Price: \$508.00



3' Box Hedge
72"W x 12"D x 36"H
Trade Show Price: \$814.00



7' Box Hedge
39"W x 12"D x 84"H
Trade Show Price: \$941.00



36" Bar Panel
36"W x 32"H
Trade Show Price: \$241.00



48" Bar Panel
48"W x 32"H
Trade Show Price: \$241.00



Clear Divider Panel
48"W x 76"H
Trade Show Price: \$786.00

ACCENTS

PONY WALLS



**Blaze Pony Wall -
Fired Steel Top**
9"W x 12"D x 4'H
Trade Show Price: \$1,015.00



**Blaze Pony Wall -
Pasadena Oak Top**
9"W x 12"D x 4'H
Trade Show Price: \$1,015.00



**Blaze Pony Wall -
White Barn Top**
9"W x 12"D x 4'H
Trade Show Price: \$1,015.00



**Corbin Pony Wall -
Fired Steel Top**
9"W x 12"D x 4'H
Trade Show Price: \$1,015.00



**Corbin Pony Wall -
Pasadena Oak Top**
9"W x 12"D x 4'H
Trade Show Price: \$1,015.00



**Corbin Pony Wall -
White Barn Top**
9"W x 12"D x 4'H
Trade Show Price: \$1,015.00



**Vortex Pony Wall -
Fired Steel Top**
9"W x 12"D x 4'H
Trade Show Price: \$1,015.00



**Vortex Pony Wall -
Pasadena Oak Top**
9"W x 12"D x 4'H
Trade Show Price: \$1,015.00



**Vortex Pony Wall -
White Barn Top**
9"W x 12"D x 4'H
Trade Show Price: \$1,015.00

STANDS, RACKS, & PEDESTALS



Alto Literature Rack
11"W x 10"D x 57"H (6 pockets)
Trade Show Price: \$192.00



Argento Literature Rack
15"W x 12"D x 54"H (10 pockets)
Trade Show Price: \$186.00



Nero Literature Rack
15"W x 12"D x 54"H (10 pockets)
Trade Show Price: \$186.00

ACCENTS

STANDS, RACKS, & PEDESTALS



Pedestals

Trade Show Price:
 14"Square x 30"H \$262.00
 14"Square x 36"H \$281.00
 14"Square x 42"H \$332.00
 24"Square x 36"H \$402.00



Pedestals

Trade Show Price:
 24"Square x 30"H \$382.00
 24"Square x 42"H \$402.00
 18"Square x 30"H \$269.00
 18"Square x 42"H \$370.00



Plexi Display Unit

17"Square x 68"H (base & top)
 17"Square x 20"H (top only)
Trade Show Price: \$542.00



Sanitizer Stand

16"W x 75"H, 59"H (without detachable sign)
Trade Show Price: \$303.00

LIGHTING



Alder Floor Lamp

63"H
Trade Show Price: \$186.00



Alder Table Lamp

22"H
Trade Show Price: \$136.00



Neutrino Floor Lamp

67"H
Trade Show Price: \$173.00



Tripod Floor Lamp

62"H
Trade Show Price: \$186.00



Tripod Table Lamp

28"H
Trade Show Price: \$136.00



Winslow Floor Lamp

70"H
Trade Show Price: \$186.00



Winslow Table Lamp

37"H
Trade Show Price: \$136.00

EXECUTIVE FURNISHINGS

DESKS, LATERAL FILES & CREDENZAS



2 Drawer Lateral File
36"W x 20"D x 29"H
Trade Show Price: \$338.00



Executive Desk
72"W x 36"D x 29"H
Trade Show Price: \$528.00



Jr. Executive Desk
60"W x 30"D x 29"H
Trade Show Price: \$509.00



Storage Credenza
66"W x 20"D x 29"H
Trade Show Price: \$446.00

CONFERENCE TABLES



42" Round Conference Table
42" Round x 29"H
Trade Show Price: \$338.00



6' Conference Table
72"W x 36"D x 29"H
Trade Show Price:
\$604.00 white
\$574.00 black/mahogany



8' Conference Table
96"W x 48"D x 29"H
Trade Show Price:
\$649.00 white
\$618.00 black/mahogany



8' White Conference Table - Charged
96"W x 48"D x 29"H
Trade Show Price: \$1,062.00



10' Conference Table
120"W x 48"D x 29"H
Trade Show Price:
\$745.00 (white)
\$712.00 (black/mahogany)



Command 6' Conference Table
72"W x 36"D x 31"H
Trade Show Price: \$604.00



Command 8' Conference Table
96"W x 48"D x 31"H
Trade Show Price: \$649.00



Command 10' Conference Table
120"W x 48"D x 31"H
Trade Show Price: \$745.00

MISCELLANEOUS OFFICE ITEMS



14 Cubic Ft. Refrigerator
20"W x 30"D x 60"H
Trade Show Price: \$669.00



2 Drawer Lateral File
36"W x 18"D x 27"H
Trade Show Price: \$224.00



2 Drawer Vertical File
15"W x 25"D x 29"H
Trade Show Price: \$167.00
18"W x 25"D x 29"H
Trade Show Price: \$217.00



4 Cubic Ft. Refrigerator
19"W x 21"D x 33.5"H
Trade Show Price: \$345.00

EXECUTIVE FURNISHINGS

MISCELLANEOUS OFFICE ITEMS



4 Drawer Lateral File
36"W x 18"D x 54"H
Trade Show Price: \$274.00



4 Drawer Vertical File
15"W x 25"D x 52"H (letter)
Trade Show Price: \$224.00
18"W x 25"D x 52"H (legal)
Trade Show Price: \$249.00



6' Rectangular Folding Table
72"W x 30"D x 29"H
Trade Show Price: \$116.00



8' Rectangular Folding Table
96"W x 30"D x 29"H
Trade Show Price: \$141.00



Bookcase
36"W x 12"D x 72"H
Trade Show Price: \$478.00



Computer Counter
48"W x 24"D x 42"H
Trade Show Price: \$249.00



Computer Desk
48"W x 24"D x 29"H
Trade Show Price: \$237.00



Locking Pedestal
24"Square x 42"H
Trade Show Price: \$497.00



Screen Flex Partition
241"W x 6'H
Trade Show Price: \$1,075.00



Storage Cabinet
36"W x 18"D x 72"H
Trade Show Price: \$274.00



Training Table
48"W x 24"D x 29"H
Trade Show Price: \$542.00

CONFERENCE SEATING



Accord Hi-Back Executive Chair
25"Square x 44"H
Trade Show Price: \$382.00



Comet Stack Chair
23"W x 22"D x 32"H (with arms)
Trade Show Price: \$186.00
23"W x 22"D x 32"H (armless)
Trade Show Price: \$173.00



Enterprise Guest Fabric Chair
24"W x 27"D x 37"H
Trade Show Price: \$229.00



Enterprise Hi-Back Fabric Chair
25"W x 27"D x 45"H
Trade Show Price: \$269.00

EXECUTIVE FURNISHINGS

CONFERENCE SEATING



Enterprise Mid-Back Fabric Chair
24"W x 26"D x 39"H
Trade Show Price: \$249.00



Goal Drafting Stool
25"W x 24"D x 48"H (with arms)
Trade Show Price: \$217.00
Goal Drafting Stool Armless
21"W x 24"D x 48"H (armless)
Trade Show Price: \$204.00



Goal Task Chair
25"W x 24"D x 39"H (with arms)
Trade Show Price: \$204.00
Goal Task Chair Armless
21"W x 24"D x 39"H (armless)
Trade Show Price: \$186.00



Space Guest Chair
26"Square x 37"H
Trade Show Price: \$212.00



Space Hi-Back Chair
25"Square x 37"H
Trade Show Price: \$249.00



Tamiri Guest Leather Chair
25"W x 27"D x 37"H
Trade Show Price: \$249.00



Tamiri Hi-Back Leather Chair
25"W x 27"D x 45"H
Trade Show Price: \$306.00



Tamiri Mid-Back Leather Chair
25"W x 27"D x 39"H
Trade Show Price: \$269.00





afir[®]

furniture rental

Rates Effective July 1, 2022-June 30, 2023

Information & Online Ordering
www.commonwealthexpo.com

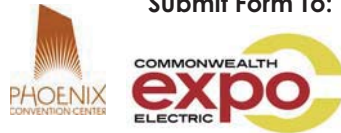

Submit Form To:

Commonwealth Electric Company
 100 North 3rd Street, Phoenix, AZ 85004
 PH 602.253.5881 Fax 602.253.5530
 Email: expo@commonwealthelectric.com

Please note that electrical orders can only be placed online or via this form, phone orders not accepted.

| | | | | | | | |
|--------------------------------------------------------------------------------------------------------------------------------------------------------------------------------------------------------------------------------------------|------------------------------------------|--------------------|------------|---------------------------------------------------------------------------------|----------------------------------------------------------------------------------------------------------------------------------------------------------------------------------------------------------------------------------------------------------------------------------------------------------------------------------------------------------------------------------------------------------------------------------------------------------------------------------|-------|-----|
| Event: <h2 style="text-align: center;">NDA 2023 Annual Convention & Expo</h2> | | | | Dates: February 21 - 26, 2023 | | | |
| For Discount Payment Price we must receive your order and payment prior to this | | | | Event # 475340 | | | |
| DISCOUNT DEADLINE DATE OF: | | | | 02/07/2023 | | | |
| Company Name: | | | | Booth#: | | | |
| Standard Electrical Outlets **Rates are for duration of event** | | | | If you require services not listed on this form please call for a quote. | | | |
| Qty | Description | Discount | Regular | | | | |
| 120V Motor & Equipment Outlets (3 Pronged) | | | | | | | |
| | 500 Watts (5Amp) | \$119.06 | \$160.73 | | Lighting, Water and/or Air, please call for Order Form | | |
| | 1000 Watts (10 Amp) | \$157.85 | \$213.09 | | | | |
| | 2000 Watts (20 Amp) | \$199.86 | \$269.81 | | | | |
| 1 Phase 208V A.C. 60 Cycle **Requires MINIMUM (1) hr Labor | | | | | | | |
| | 10 Amp 208V 1 Phase | \$269.14 | \$363.33 | | 24 Hour Services: Rates are DOUBLE the Outlet Rate <input type="checkbox"/> Check if required | | |
| | 20 Amp 208V 1 Phase | \$316.83 | \$427.72 | | | | |
| | 30 Amp 208V 1 Phase | \$395.18 | \$533.49 | | Overhead Power: Rates are Time and Material. Please call for quote. | | |
| | 50 Amp 208V 1 Phase | \$539.40 | \$728.18 | | | | |
| | 60 Amp 208V 1 Phase | \$612.08 | \$826.30 | | | | |
| | 100 Amp 208V 1 Phase | \$986.08 | \$1,331.20 | | | | |
| 3 Phase 208V A.C. 60 Cycle **Requires MINIMUM (1) hr Labor | | | | | | | |
| | 10 Amp 208v 3 Phase | \$304.33 | \$410.85 | | 208V and 480V Services: There is a MINIMUM labor charge of (1) hr. for installation/removal of all 208V service. There is a MINIMUM labor charge of (2) hrs. for installation/removal of all 480V service. | | |
| | 20 Amp 208V 3 Phase | \$424.70 | \$573.35 | | | | |
| | 30 Amp 208V 3 Phase | \$468.75 | \$632.81 | | | | |
| | 50 Amp 208V 3 Phase | \$677.30 | \$914.36 | | | | |
| | 60 Amp 208V 3 Phase | \$821.53 | \$1,109.07 | | | | |
| | 100 Amp 208V 3 Phase | \$1,511.91 | \$2041.07 | | | | |
| Rental Items | | | | | | | |
| | Extension Cord 15' | \$32.19 | | | ELECTRICAL LABOR: Outlets requested to be placed anywhere other than the back of the booth will require a layout and a MINIMUM of (1) hour labor. Please call for quotes on labor if your booth is an Island booth or needs overhead power. <input type="checkbox"/> Okay to proceed (layout with scaled orientation attached. Order will be installed prior to exhibitor move in. <input type="checkbox"/> Layout to follow | | |
| | Extension Cord 25' | \$34.57 | | | | | |
| | 5-way power strip | \$29.81 | | | | | |
| | 3-way adaptor | \$26.23 | | | | | |
| In line booths with standard electrical placement (along back drapeline) will NOT incur labor charges | | | | | | | |
| Labor for Layout/Overhead/Qty and 208V Services | | | | | | | |
| | ST (M-F 8am-4:30pm) | \$104.92 | | | FOR SUPERVISED LABOR ONLY Exhibitor supervision requested, requires a MINIMUM of (1) hour of labor. Date/Time Requested Onsite Contact Onsite Contact Cell # | | |
| | OT (M-F 4:30pm-12am & Sat 8am-12am) | \$157.39 | | | | | |
| | DT (M-F 12am-8am & all Sundays/Holidays) | \$209.85 | | | | | |
| State of Arizona or Federal Tax Exempt form must be submitted with order to receive exemption. **By signing the order form, I have read and agree to all of Commonwealth Electric Company's Conditions and Regulations.** | | | | Total Order | | | |
| | | | | 8.6% Sales Tax | | | |
| | | | | Labor Amount | | | |
| | | | | Total Due | | | |
| Company Name | | | | Phone | | | |
| | | | | Cell Phone | | | |
| Address | | | | City | | State | Zip |
| Email Address | | | | Onsite Contact | | | |
| Signature | | | | Print Name | | | |
| Paid by: CK AX MC VS | | Credit Card Number | | | Exp Date | | CVV |
| Cardholder Signature | | | | Print Name | | | |



| | |
|------------------------------------------------|----------------------------------------|
| Event: | Dates February 21 - 26, 2023 |
| <h1>NDA 2023 Annual Convention & Expo</h1> | Event # 475340 |

For Discount Payment Price we must receive your order and payment prior to this

DISCOUNT DEADLINE DATE OF

02/07/2023

| | |
|---------------|---------|
| Company Name: | Booth # |
|---------------|---------|

| Air/Water Service | | | | |
|-------------------------------------------------------------------------------------------|--------------------------------------------------------------|----------|----------|--------|
| Qty | Description | Discount | Regular | Amount |
| Compressed Air Service | | | | |
| | 1/4" Quick Connect Coupler | \$245.28 | \$331.13 | |
| | 1/2" Quick Connect Coupler | \$245.28 | \$331.13 | |
| Water Fill (One Time Fill) | | | | |
| | Up to 50 Gallons | \$105.61 | \$142.57 | |
| | 51-500 Gallons | \$264.59 | \$357.20 | |
| | 501-1000 Gallons | \$329.32 | \$444.58 | |
| | Additional Water-per 1000 Gallons (Over 1000 only) | \$256.64 | \$346.46 | |
| Continuous Water | | | | |
| | Continuous Supply, Connect or Disconnect NOT included | \$250.96 | \$338.80 | |
| Do you need a drain? (Check One) <input type="checkbox"/> Yes <input type="checkbox"/> No | | | | |
| Please contact us for availability of potable water. | | | | |

If you require services not listed on this form please call for a quote.

Water Connection includes 3/4" hose thread, water, shutoff valve and drain hose with 3/4" standard thread.

A detailed floor plan must be submitted with each Water and/or Air Order to ensure proper placement.

A Representative must be in the booth or a fill line must be clearly marked before the fill can be completed.

Additional labor charge will apply for refills of water or if your water is requested to be turned on/off throughout the duration of the event. See rates below.

| Water Labor | Connect Date/Time |
|-----------------------------------------------------------------------------------------------------------------------------------|-----------------------|
| ST (M-F 8am-4:30pm) | |
| OT (M-F 4:30pm-12am & Sat 8am-12am) | |
| DT (M-F 12am-8am & all Sundays/Holidays) | |
| | Disconnect Date/Time |
| State of Arizona or Federal Tax Exempt form must be submitted with order to receive exemption. | Total Order |
| | 8.6% Sales Tax |
| | Labor Amount |
| | Total Due |
| **By signing the order form, I have read and agree to all of Commonwealth Electric Company's Conditions and Regulations.** | |

| | | |
|-----------------------------------|--------------------|-----------------|
| Company Name | Phone | Cell |
| Address | City | State Zip |
| Email Address | Onsite Contact | |
| Signature | Print Name | |
| Paid by: CK AX MC VS | Credit Card Number | CVV Exp Date |
| Cardholder Signature | Print Name | |

Terms and Conditions



Payment Policy:

1. **Payment in full:** is required on all orders at the time the order is placed. Purchase orders are not considered payment. There will be an additional \$35 service charge on all returned checks. For your convenience, we accept the following forms of payment: Check, Money Order, Visa, MasterCard and American Express. No cash will be accepted.
2. **Tax:** All amounts, except labor, are subject to a combined Arizona State and City sales tax. If you are tax exempt in the state of Arizona, please attach sales tax exemption certificate (form 5000) to your order. Orders submitted online will not be accepted as tax exempt, and credit will not be given for sales tax paid online. Tax exempt orders must be submitted with the order form and not placed online.
3. **Discount Rates:** Please see order form for exact date for each event.
4. **Regular Rates:** are applied to all orders received after the deadline for the discounted rates and orders received on-site at the event.
5. **Refunds:** will not be issued on services that have already been installed. Refunds will not be considered unless submitted in writing by customer prior to the close of the event.
6. **Contract Agreement:** Lessor will not be responsible for strikes, accidents, an Act of God, or delays beyond control. If by any reason of any default on the part of the lessee, hereunder, it becomes necessary to engage an attorney, the lessee agrees to pay all costs, expenses, and the attorney's fees expanded or incurred by lessor in connection therewith. Payment or receipt of this contract constitutes acknowledgment that lessee has read and agrees to all conditions and regulations as stated in this contract.

Outlets & Equipment:

1. All electrical outlets are provided at an additional charge and are not part of a booth package unless otherwise indicated on the Commonwealth Electric order form.
2. Each outlet ordered is ONE (1) SINGLE plug-in.
3. In-line and peninsula booths: each outlet will be located at the back of the booth. Island booths: outlets will be placed at the most convenient location for Commonwealth Electric unless otherwise noted by the customer. Should outlets be required in any other location within the booth, a labor charge will be incurred, and a layout must be submitted with order.
4. Outlets are to be ordered separately by each customer and may not be shared with other customers.
5. Building utility outlets are not a part of the booth space and are not to be accessed, blocked or used by customers.
6. Electrical floor boxes must not be covered or blocked by customer unless prior arrangements have been made with Commonwealth Electric.
7. All materials and equipment furnished by Commonwealth Electric for this service order, shall remain the property of Commonwealth Electric and shall only be removed by Commonwealth Electric at the close of the event. Any equipment removed by the customer shall be charged the replacement cost of the specific equipment.

Labor:

Labor charges shall be incurred for the following: (please refer to the order form or contact Commonwealth Electric for labor minimums per service)

- Request for your outlet to be placed anywhere other than the back of your booth. A layout must be attached to your order with booth orientation & dimensions.
- All 110V (120V) services above 20 amps.
- All 208V (220V) services ordered with a minimum of one (1) hour labor per connection.
- Conversion of customer power connection.
- All overhead services.
- Ordering eight (8) or more services within the same booth space.
- Requested customer supervision for service installation.

Conditions and Regulations:

1. Commonwealth Electric will provide standard NEMA connections for all services 208V (220V) or higher. Please check with Commonwealth Electric for specific type of connection per facility. It is the responsibility of each customer to convert to each facility's connection.
2. Customers are responsible for supplying all converters 220V-110V for international equipment. Should Commonwealth Electric supply, there will be an additional charge. Contact Commonwealth Electric for specific charges.
3. Commonwealth Electric will not be responsible for any cutting or altering of any floor covering in order to bring services to a booth in a specific location.
4. All equipment, regardless of source of power, must comply with all Federal, State, and City safety codes.
5. All equipment must be approved by Underwriters Laboratory and properly UL labeled with complete information as to current, voltage, phase, cycle, horsepower, etc. If equipment is not UL approved and tagged, Commonwealth Electric reserves the right to refuse to energize.
6. All customer supplied cords must be of the three (3) wire grounded type. Use of open sockets, latex or lamp cord wire is prohibited.
7. All exposed, non-current carrying metal parts of fixed equipment, which are liable to be energized, shall be grounded.
8. Commonwealth Electric is not responsible for voltage fluctuations or power failure because of temporary conditions.

FAQ:

1. How much power do I need to order?

Answer: You will need to check the electrical tag/sticker on each piece of equipment to determine the actual wattage or amperage required. Please feel free to contact the Commonwealth Electric Account Manager for your event if you need assistance.

2. How much power will I need to order for a laptop?

Answer: You may power up to three (3) laptops per 500-watt outlet ordered.

3. How much power will I need to order for lighting?

Answer: Please add up the wattage of each lightbulb to determine total amount of wattage needed to order. Example: Four (4) sixty (60) watt lightbulbs would total two hundred forty (240) watts. You would need to order a 500-watt outlet to power these lights.



Becky's Phoenix Plants, LLC

2022 SHOW
RENTAL
ORDER FORM

PO Box 42448, PHX, AZ. 85080

Phone: 602-410-7633

office@beckysphoenixplants.com

Becky (Owner/Designer): 602-410-7633

www.beckysphoenixplants.com

* Blooming plant colors very upon season.

*Becky's Phoenix Plants, LLC can provide banquet center prices and VIP amenities for hospitality rooms and hotel rooms.

* Contact us for items not listed ~ Southwest theme, Cactus bowls ect. () Please have Becky ~

designer meet me at my booth. Date:

Time: _____ AM/PM Contact name _____

Phone number _____ * Terra Cotta pots are an

additional charge **

WE ARE HERE FOR YOU 24/7 **

| QTY | CUSTOMER FLORAL DESIGNS | PRICE | TOTAL |
|-----|------------------------------------------------------------|---------------|-------|
| | FLORAL 12" : TROPICAL ~ TRADITIONAL Color & Size Shape, | \$65.00 & up | |
| | FLORAL 18" : TROPICAL ~ TRADITIONAL Color & Size Shape, | \$95.00 & up | |
| | FLORAL 24" : TROPICAL ~ TRADITIONAL Color & Size Shape, | \$150.00 & up | |
| | BOUQUETS/CORSAGE (opt. on flower in season) | \$40.00 & up | |
| | Bubble bowl 8" ~ Business cards/Candy etc... | \$40.00 & up | |

| QTY | BLOOMING PLANTS | PRICE | TOTAL |
|-----|----------------------------------------------------|---------|-------|
| | MUM 6" : Yellow _____ White _____ Purple _____ | \$18.50 | |
| | AZALEA 6" : Red _____ Pink _____ White _____ | \$25.00 | |
| | KALANCHOE 6" : Red _____ Yellow _____ Orange _____ | \$20.00 | |

| QTY | TROPICAL PLANTS | PRICE | TOTAL |
|-----|----------------------------|---------|-------|
| | SMALL FERNS ~ 6" or plants | \$17.00 | |
| | LARGE FERNS ~ 8" | \$35.00 | |

| | | | |
|--|-----------------------------------------------------------|----------------|--|
| | 3 - FOOT PLANT | \$39.00 | |
| | 4 - FOOT PLANT | \$49.00 | |
| | 5 - FOOT PLANT | \$59.00 | |
| | 6 - FOOT PLANT | \$80.00 | |
| | 7 - FOOT PLANT | \$89.00 | |
| | 8 - FOOT PLANT | \$95.00 | |
| | 10 - FOOT PLANT OR TALLER | Call for Quote | |
| | CACTUS - SOUTHWESTERN THEME | Call for Quote | |
| | LIGHTING FOR PLANTS (TWINKLE, UP & CAN) | Call for Quote | |
| | ASSORTED CONTAINERS AVAILABLE (Black/White pots, Baskets) | | |

| Services/NOTES: | SUBTOTAL | TOTAL |
|-----------------|------------------------------|-------|
| | SALES TAX 8.6% | |
| | DELIVERY \$18 over \$200/20% | |
| | TOTAL | |

NATIONAL DEMOLITION ASSOCIATION

FEBRUARY 23-25 2023

PHOENIX CONVENTION CENTER

EXHIBITOR INFORMATION

BOOTH #:

Company Name:

Address:

City: State: Zip:

Contact:

Phone: Fax:

PAYMENT METHOD:

CASH ~ CHECK ~ CREDIT CARD

VISA ~ MASTERCARD ~ AMEX

X _____

Cardholder's name

_____ EXP# _____

Credit Card Number CCV# ZIP#

* The undersigned acknowledges receipt of

the merchandise described herein and agrees to assure the replacement cost for any loss or damage to said merchandise which is the property of Becky's Phoenix Plants, LLC. No adjustments after close of the show.

X _____

Date: _____